

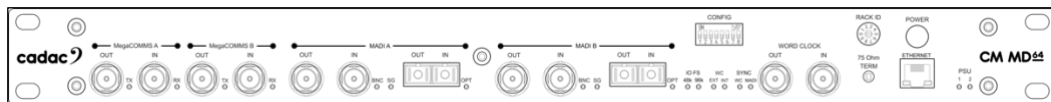

Cadac MADI Network Bridge



CM-MD64 Hardware Overview

Left Intentionally Blank

Table of Contents

Important Safety Information	4
For US and CANADA Only	4
General Precautions	5
Declaration of Conformity	6
Introduction	9
Overview	10
Front Panel Controls	10
Rear Panel	11
Shipping Details	11
Remote Network Bridge Units	12
MADI Bridge Overview	13
MegaCOMMS: Data Protocol	14
CM-MD64 MADI Bridge Hardware Overview: Front Panel	15
Front Panel	15
Connecting the Hardware	17
MegaCOMMS	17
System Connection Options	18
Setting up the CM-MD64 for a MADI Network	22
Front Panel Dip Switch Settings	22
Important Notes	22
Appendix A: Example System Configurations	23
System 1	23
System 2	24
System 3	25
System 4	25
Appendix B: Updating Firmware	26
Programming the FPGA	26
When the FPGA Has Been Programmed	27
Appendix C	28
Technical Specifications	28
Dimensions and Weights	29
Notes:	30

Important Safety Information

CAUTION: These servicing instructions are for use by qualified personnel only. To reduce the risk of electric shock, do not perform any servicing other than that contained in the User Manual unless you are qualified to do so. Refer all servicing to qualified service personnel.

1. Read these instructions.
2. Keep these instructions.
3. Heed all warnings.
4. Follow all instructions.
5. Do not use this apparatus near water. Do not expose this apparatus to dripping or splashing and ensure that no objects filled with liquids, such as vases, are placed on this apparatus.
6. Clean only with a dry cloth.
7. Do not block any of the ventilation openings. Install in accordance with the manufacturer's instructions.
8. Do not install near any heat sources such as radiators, heat registers, stoves, or other apparatus that produce heat.
9. Only use attachments/accessories specified by the manufacturer.
10. Refer all servicing to qualified service personnel. Servicing is required when the apparatus has been damaged in any way, such as the power-supply cord or plug is damaged, liquid has been spilled or objects have fallen into the apparatus, the apparatus has been exposed to rain or moisture, does not operate normally, or has been dropped.
11. To completely disconnect mains power from this apparatus, the power supply cord must be unplugged.

For US and CANADA Only

Do not defeat the safety purpose of the grounding-type plug. A grounding-type plug has two blades and a third grounding prong. The wide blade or the third prong is provided for your safety. When the provided plug does not fit into your outlet, consult an electrician for replacement of the obsolete outlet.



The lightning flash with arrowhead symbol, within an equilateral triangle is intended to alert the user to the presence of an uninsulated "dangerous voltage" within the product's enclosure that may be of sufficient magnitude to constitute a risk of electric shock to persons.



The exclamation point within an equilateral triangle is intended to alert the user to the presence of important operating and maintenance (servicing) instructions in the literature accompanying the appliance.

General Precautions

- Do not place heavy objects on the Network Bridge, expose it to sharp objects or handle the unit in any way that may cause damage, e.g., rough handling and /or excessive vibration.
- Do not subject the equipment to dirt, dust, heat or vibration during operation or storage. Never expose the Network Bridge to rain or moisture in any form. Should the unit become wet, turn it off and disconnect it from the mains without further delay. The Network Bridge should be given sufficient time to dry out before recommencing operation.
- When cleaning the Network Bridge, never use chemicals, abrasive substances or solvents.
- The Network Bridge should be cleaned using a soft brush and a dry lint-free cloth. For persistent marks, use a soft cloth and isopropyl alcohol. Switches and potentiometers do NOT require cleaning or lubrication.
- Keep these instructions for future reference. Follow all warnings in this manual and those printed on the console.
- The Network Bridge must be connected following the guidance in this manual. Never connect power amplifier outputs directly to the unit. Connectors and plugs must never be used for any other purpose than that for which they are intended.
- The Network Bridge's mains input must always be connected to correctly rated mains power as referred to in this manual. The mains input must, at all times, be connected to the local mains power supply using the supplied power cord. In cases where the supplied plug does not fit, a qualified electrician must be consulted.
- The power cord must be routed in such a way that the risks of accidentally stepping on it, stretching it or it being pinched are minimized.
- **WARNING! THIS EQUIPMENT MUST BE EARTHED!**
- Ventilation slots must never be covered or obstructed in any way, otherwise airflow required for safe operation may be restricted. Where the Network Bridge is to be operated in a flight-case, then this must be located in such a way that it allows for proper ventilation.
- Refer servicing to qualified technical personnel only.

Declaration of Conformity

The following pages show the individual declarations of conformity, for both the CE and UKCA marks, for the Cadac CM-MD64 MADI audio network bridge.

We, SCC Audio Limited, of 1 New Street, Luton, Bedfordshire, LU1 5DX declare under our sole responsibility that the **Cadac CM-MD64** MADi bridge, as detailed below complies with the provisions of the following UKCA Directives and is eligible to bear the UKCA mark:

CM-SR Series

Product Type Number	Product Description	Serial number
Cadac CM-MD64	Network Bridge	0000000000

Object of the declaration:



The CM-MD64 is a MADi to MegaCOMMS audio network bridge allowing the seamless integration of MADi audio streams into a MegaCOMMS audio network. The 1U unit can operate at 96 kHz or 48 kHz and can handle up to 64 inputs and outputs and is equipped with 128 channels with SRC as well as its own independent word clock.

Assurance of conformance of the described product with the provisions of the stated UK Regulation is given through compliance to the following standards:

EMC Directive: **2014/30/EU**
 Low Voltage Directive: **2014/35/EU**

The following harmonised standards and technical specifications have been applied:

Electrical Safety (LVD): **EN 62368-1:2014/AC:2015**
 Electromagnetic Compatibility: **EN55032:2015**
EN55013:2013+A1:2016
EN61000-3-2:2019
EN61000-3-3:2013 + A1. 2019
EN61000-4-2:2009
EN61000-6-2:2019
EN55035:2017/A11:2020

Our representative in the UK is SCC Audio Limited, located at 1 New Street, Luton, Bedfordshire, LU1 5DX.

Note: The EMC performance of a system component will be affected by the final installation, compliance to the stated EMC standards and conformance to the EMC Directive must be confirmed after installation by the final equipment installer. For guidance with respect to test conditions please visit our website at <https://cadac-sound.com>, or contact your local CADAC representative.

Signed for on behalf of:

Name of Authorised Signatory	Emily Watson
Signature of Authorised Signatory	
Position of Authorised Signatory	Head of R&D Cadac
Date	21 st October 2022
Date when first CE marked	1 st March 2014
Place where signed	Luton, UK



CM-SR Series

We, SCC Audio Limited, of 1 New Street, Luton, Bedfordshire, LU1 5DX declare under our sole responsibility that the **Cadac CM-MD64** MADI bridge, as detailed below complies with the provisions of the following European Directives and is eligible to bear the CE mark:

Product Type Number	Product Description	Serial number
Cadac CM-MD64	Network Bridge	0000000000

Object of the declaration:



The CM-MD64 is a MADI to MegaCOMMS audio network bridge allowing the seamless integration of MADI audio streams into a MegaCOMMS audio network. The 1U unit can operate at 96 kHz or 48 kHz and can handle up to 64 inputs and outputs and is equipped with 128 channels with SRC as well as its own independent word clock.

Assurance of conformance of the described product with the provisions of the stated EC Directive is given through compliance to the following standards:

- EMC Directive: **2014/30/EU**
- Low Voltage Directive: **2014/35/EU**

The following harmonised standards and technical specifications have been applied:

- Electrical Safety (LVD): **EN 62368-1:2014/AC:2015**
- Electromagnetic Compatibility: **EN55032:2015**
- EN55013:2013+A1:2016**
- EN61000-3-2:2019**
- EN61000-3-3:2013 + A1. 2019**
- EN61000-4-2:2009**
- EN61000-6-2:2019**
- EN55035:2017/A11:2020**

Note: The EMC performance of a system component will be affected by the final installation, compliance to the stated EMC standards and conformance to the EMC Directive must be confirmed after installation by the final equipment installer. For guidance with respect to test conditions please visit our website at <https://cadac-sound.com>, or contact your local CADAC representative.

Signed for on behalf of:

Name of Authorised Signatory	Emily Watson
Signature of Authorised Signatory	
Position of Authorised Signatory	Head of R&D Cadac
Date	21 st October 2022
Date when first CE marked	1 st March 2014
Place where signed	Luton, UK

Introduction

Thank you for purchasing this Cadac CM-MD64.

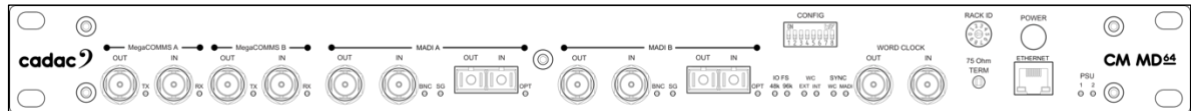

From its founding in 1968, Cadac’s products have become the benchmark for audio mixing consoles. The CM Series continues this tradition with a live performance digital audio system benefiting from Cadac’s innovative and acclaimed user interface, superlative audio quality and industry leading low latency infrastructure.

It expands the audio performance and features developed over a 50-year period of innovation within large-scale theatre and touring analogue desks and puts them within a compact, fixed-architecture digital system, featuring a “high-agility” user interface utilising a wide format touch screen. Professional sound engineers familiar with other digital consoles will find the transition to the Cadac workflow quick and intuitive.

Cadac’s attention to detail and high-quality audio circuitry remains at the core of Cadac’s CM Series design philosophy.

Overview

The Cadac CM-MD64 unit is used as part of a larger audio system made up of multiple units: digital mixing console(s) and remote MegaCOMMS I/O device(s). The CM-MD64 is an audio network bridge enabling MADI units to be incorporated within Cadac's MegaCOMMS audio network.

Front Panel Controls

The front panel is divided in four operational areas:

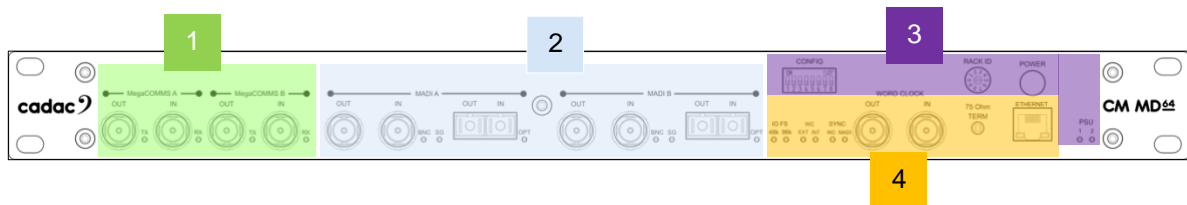

1. **MegaCOMMS Ports:** MegaCOMMS audio interconnections available on two pairs of redundant BNC connections.
2. **MADI Channels:** Two MADI channels - A and B - each with BNC co-axial and duplex optical LC connections.
3. **Config. Dip Switch, Hex Switch and Power:** A dip switch for configuring the unit's sample rates and Word Clock modes. The Hex switch sets the unit's rack number when connecting to a Cadac console. Plus, a front power button to power up the unit.
4. **Word Clock:** Word Clock connector for an external clock, with status lights, plus an Ethernet port.

Rear Panel

The only connections that are not on the front panel are the power connections for the dual internal, auto switching, power supplies. The connectors accept the standard and locking IEC cables.

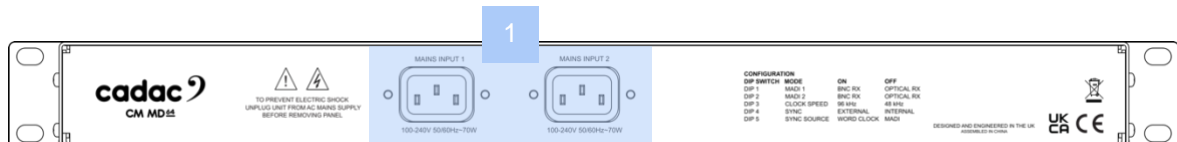

1. **PSU connectors:** The dual internal PSUs have an input range of 100-240 V AC~50-60Hz, the output requirements are +17 V, -17 V, +12 V, with a front mounted power switch. The unit is designed to run off one PSU, however when connected the second supply provides redundancy.

For further detailed explanation of the control surface please see section: [MADI Overview: Front Panel](#)

Shipping Details

The stage rack is shipped in a cardboard box with the following additional items:

- 2 x IEC locking power cables

Remote Network Bridge Units

Two remote network bridges are available:

- CM-MD64: 1U MADI Network Bridge: 64 inputs and outputs at 96 kHz, 88.2 kHz, 48 kHz or 44.1 kHz operation

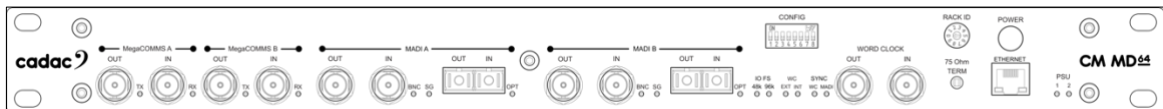

- CM-DT64: 1U Dante Network Bridge: 64 inputs and outputs at 96 kHz, 88.2 kHz, 48 kHz or 44.1 kHz operation

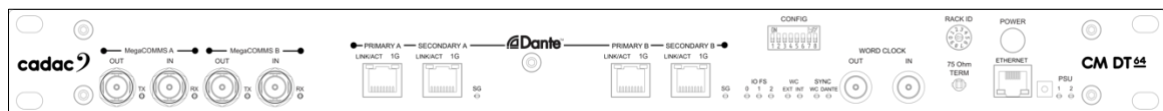

Up to two MegaCOMMS remote network bridges devices can be connected directly to the console.

MADI Bridge Overview

The Cadac CM-MD64 is a 1U, MADI to MegaCOMMS audio network bridge, enabling MADI units to be incorporated within a MegaCOMMS audio network. The unit supports up to 64 bi-directional connections to map between MegaCOMMS ports and a MADI network.

The unit features two MADI ports to provide the 64 input and output channel count at 96 kHz. Each MADI stream has the option of BNC co-axial for connection up to 100m, or duplex optical LC ports for connections of up to 2km.

CM-MD64 can operate at either 96 kHz or 48 kHz, providing 64 bi-directional channels. The unit also has an internal independent Word Clock.

The BNC co-axial ports glow either red or blue for Rx (receive) or Tx (transmit).

The CM-MD64 also comes as standard with redundant, auto switching, internal PSUs. Cooling of the unit is done via convection.

MegaCOMMS: Data Protocol

Communication between the unit and the console is via a proprietary Cadac high speed protocol called MegaCOMMS. The protocol uses high-speed 75 ohm coaxial cable terminated in BNC connectors or depending on the unit, via fibre optic cable using the duplex optical LC ports.

MegaCOMMS is a robust, TDM (time division multiplex) system. Control data is embedded within the data stream, so that no audio channels are sacrificed for this purpose. The high bandwidth available means that the current implementation of MegaCOMMS can carry 128 channels of 24-bit, 96 kHz audio, plus control data, plus clock, bi-directionally, up to 100 metres (328 ft) via a pair of RG-6 coaxial cables and up to 2km (1.24 miles) via single mode fibre on optical.

In addition to audio and control data, MegaCOMMS provides for accurate, phase-aligned clock distribution, by embedding timing markers in the data stream. This allows reliable, low-jitter synchronisation of all hardware elements within a network.

The simplest implementation of a MegaCOMMS network is the straightforward console-stage rack configuration. In this application, the console provides the clock and the stage rack synchronises itself once the connections are made. Total through-system propagation delay for this system, including all console processing and A-D / D-A conversions is an astonishing 37 samples (@ 96 kHz), or just under 400us. This compares with the many millisecond propagation delays usually found in most other similar systems.

Two interconnection paths are provided, A and B, each of which requires a transmit and receive cable. The maximum capacity of each path is 128 audio channels in each direction.

CM-MD64 MADI Bridge Hardware Overview: Front Panel

Front Panel

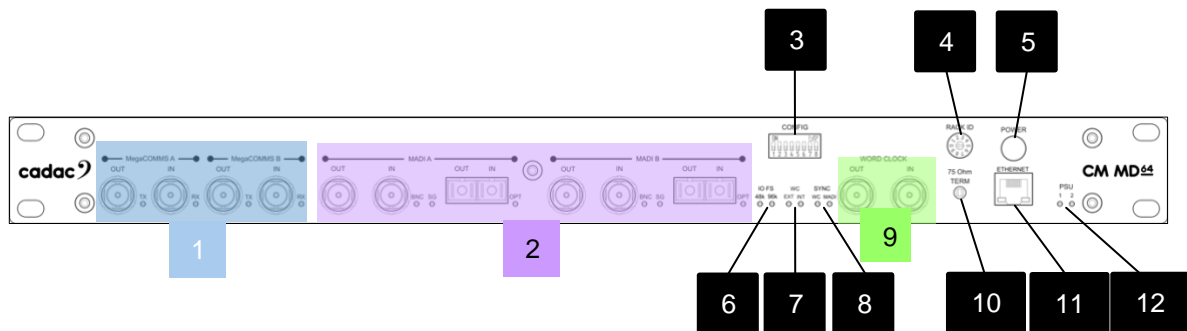

1. **MegaCOMMS ports:** 4 x RG6 BNC connectors - in 2 pairs – carry all audio and control data between the control surface and other MegaCOMMS devices such as stage racks and consoles. Each individual port has a signal present LED.
2. **MADI Ports:** Two network ports **A** and **B** are available to provide the 64 bi-directional channel count required at 96 kHz (32 bi-directional channels at 96 kHz per MADI port (A and B), otherwise 64 bi-directional channels at 48 kHz via Port A) – either on BNC coax or duplex optical LC ports [See [Appendix A](#) for example diagrams]. The optical connection can carry the audio stream up to a distance of 2km. Each type of connector has a LED indicating successful receipt of data (SG).
3. **Config:** The dip switch is used to set both the sample rates for the unit along with Word Clock modes and whether the unit uses its INTERNAL clock or follows and EXTERNAL clock. For more information refer to section: Front Panel Dip Switch
4. **Rack ID Hex Switch:** The hex switch controls the rack address and is set depending on how the unit is to be connected:
 - Set to '2' when connecting the CM-MD64 to a console, and it is to be used as RACK 1
 - Set to '3' when connecting the CM-MD64 to a console, and it is to be used as RACK 2

NOTE: Always set the rack address while the unit is OFF or restart the unit if changed while it was ON.
5. **POWER:** Switches the unit ON / OFF

6. **IO FS:** Indicates the sample rate (FS) of the inputs and outputs.

7. **WC:** Word Clock status. **EXT-LED** indicates the unit is set to follow an external clock; **INT-LED** shows the unit is set to CM-MD64's internal clock. For more information refer to the section: [Front Panel Dip Switch Settings](#)

8. **SYNC:** Synchronisation status. The **WC-LED** indicates the unit is FOLLOWING a Word Clock connected to the **Word Clock IN** BNC [9]. The **MADI-LED** indicates the unit is FOLLOWING a Word Clock set by a third-party unit within MADI network that is connected to the **MADI Ports** [2]. If both LEDS are OFF, the CM-MD64 is acting as the Word Clock for the network.

9. **Word Clock IN / Word Clock OUT:** Word Clock IN or OUT - on BNC connectors for 75 ohm co-axial cable - to ensure the synchronisation of the digital signal with the network.

10. **75 ohm switch:** The recessed switch is the input termination for the Word Clock. When pressed the impedance is set at 75 ohm for use with 75 ohm coax cable.

11. **Network:** RJ45 Ethernet port for updating the unit's firmware. This is a standard PC network Gigabit Ethernet port.

12. **PSU indicators:** LEDs indicate the ON status of each of the two internal power supplies.

Connecting the Hardware

MegaCOMMS

Cadac's proprietary MegaCOMMS hi-speed data protocol is used to interconnect the network bridge to the console. The CM-MD64 MADI network bridge and the console have four BNC sockets to provide the main system data interconnection, labelled OUT (TX) A, IN (RX) A and OUT (TX) B, IN (RX) B:

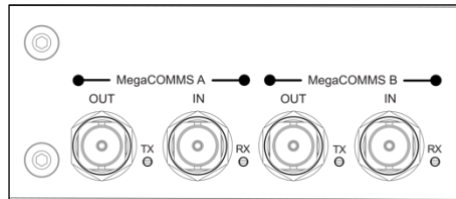

1: The CM-MD64 has two pairs of MegaCOMMS ports on BNC connectors

Cadac consoles have two pairs of BNC sockets, plus two optical ports for MegaCOMMS:

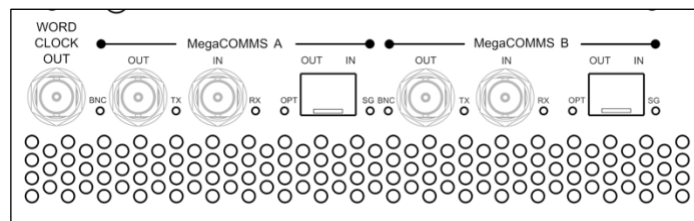

2: Cadac consoles have two pairs of MegaCOMMS ports on BNC connectors and two duplex optical LC ports

The two paths, A and B, carry identical and synchronous data, and can be used in various ways, depending on whether system redundancy is required. Providing a redundant path gives greater system robustness, as the CM-MD64 will automatically switch its comms to Path B if communication is lost on Path A, such as might occur if a cable is damaged. Note that the CM-MD64 is fully functional in all respects if only one coax TX / RX or optical path is connected.

System Connection Options

The console and CM-MD64 should be connected using one of the system configurations shown over the next few pages. The diagrams depict systems in redundant or non-redundant configurations.

IMPORTANT: Best Practice when Designing a System

With coaxial cable it is best practice **NOT** to tape power cables to the coaxial cable. This could lead to interference with the signal and result in unwanted audio artefacts, or in the worst case, total loss of audio. It is highly recommended that **all coaxial cables be connected** to the appropriate units **prior to powering** them on.

When designing a system, it is extremely important to ensure that the **coaxial cable runs do not exceed 100m and fibre optic cables do not exceed 2km.**

When using **redundancy**, the optical and coaxial runs from the console to the unit (s) must not exceed 2km or 100m respectively - and must be of **similar lengths**. The coaxial link cables connecting the two units must not exceed 100m

When designing a non-redundant, redundant or daisy chain system, MegaCOMMS port A or B from the console **MUST** be connected to **MegaCOMMS port A** - NOT port B - on the CM-MD64 and /or the stage rack. Any redundancy link cables must use ports B on both units.

Console with a CM-MD64 and CM-SR stage rack: Non-Redundant System

System below using one CM-MD64 and CM-SR stage rack using coaxial cables only

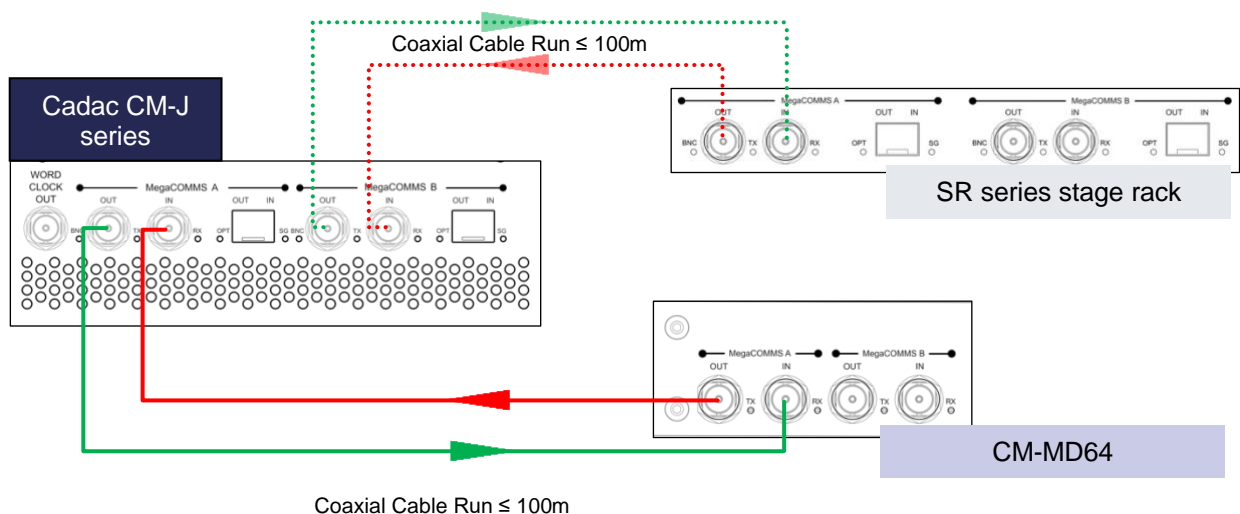

NOTE: With the system setup above MegaCOMMS PORT A on the CM-MD64 and stage rack **MUST** be connected to the console.

System below using one CM-MD64 and CM-SR stage rack with the CM-SR rack using fibre optic cable

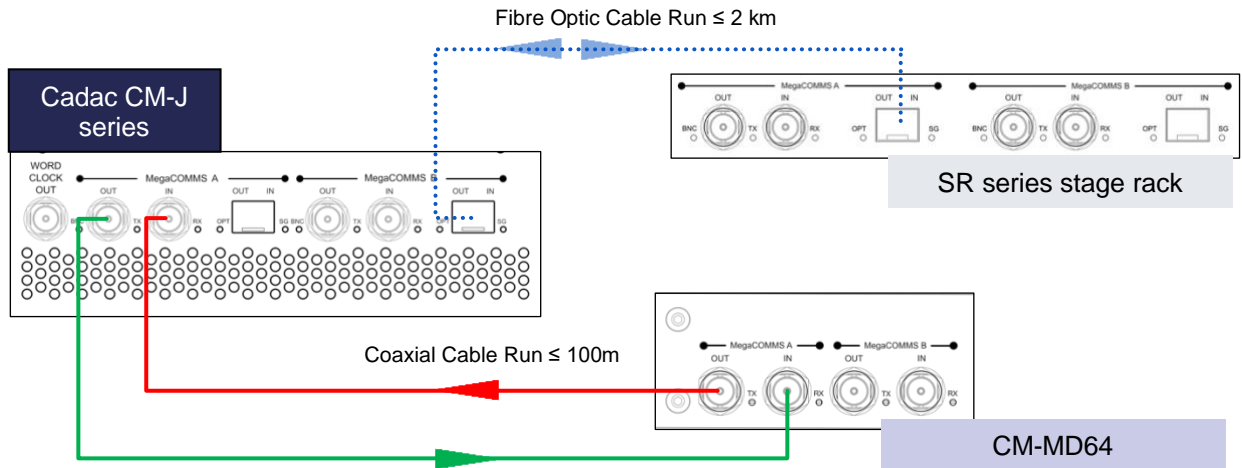

NOTE: With the system setup above MegaCOMMS PORT A on the CM-MD64 and stage rack MUST be connected to the console.

Console and CM-MD64: Redundant System

System below using one CM-MD64 using coaxial cables only

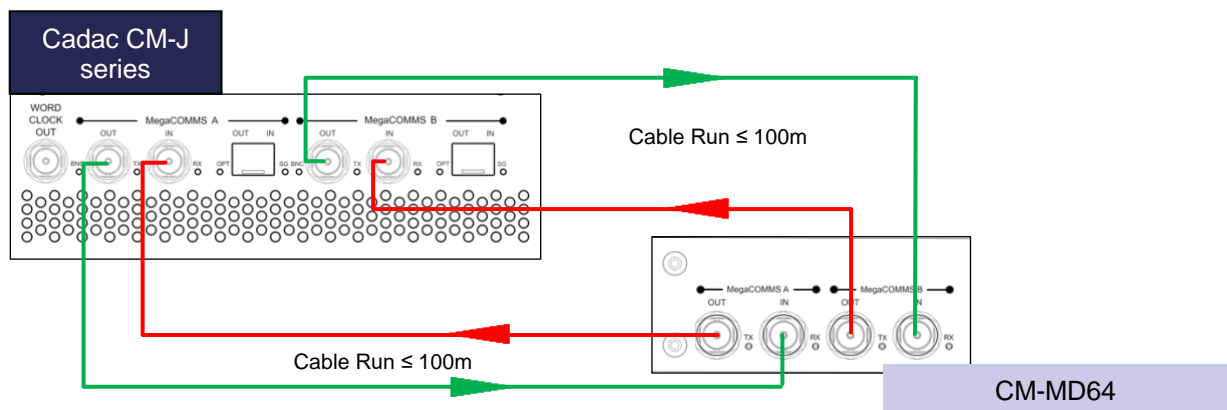

NOTE: The coaxial cables within the system must be of similar length.

System below using one CM-MD64 and CM-SR stage rack using coaxial cables only

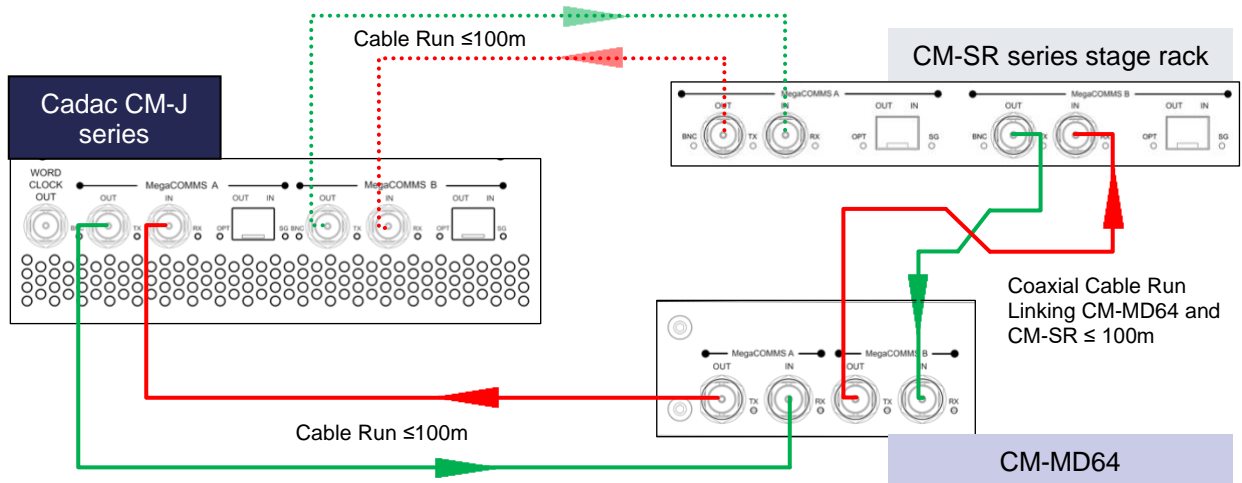

NOTE: With the system setup above MegaCOMMS *PORT A* on the CM-MD64 and stage rack **MUST** be connected to the console. The coaxial cables linking the console to the racks must be of similar length.

System below using one CM-MD64 and CM-SR stage rack with the CM-SR using fibre optic cable

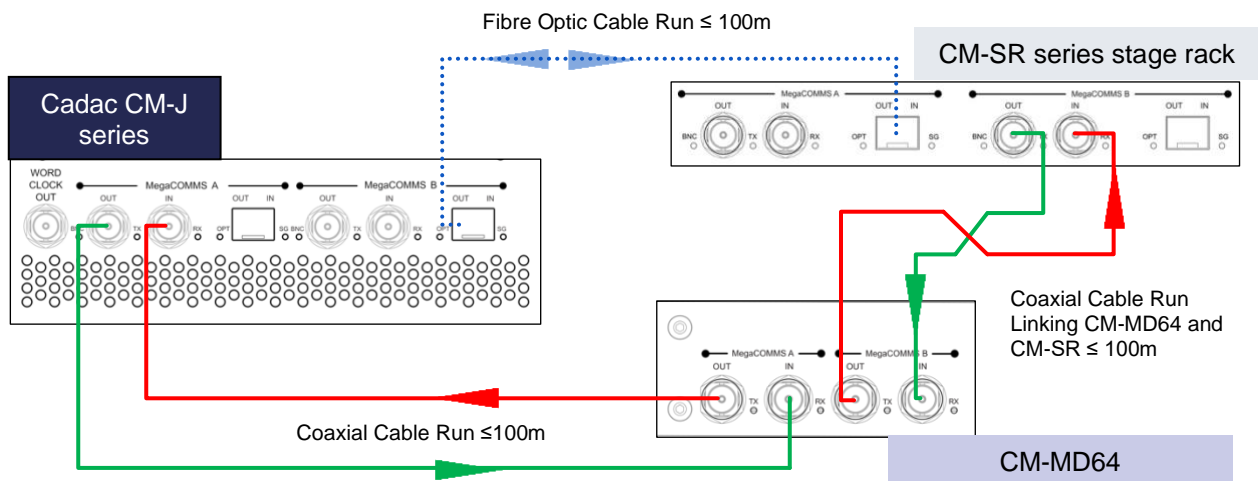

NOTE: With the system setup above MegaCOMMS *PORT A* on the CM-MD64 and stage rack **MUST** be connected to the console.

Console and daisy chaining one CM-MD64 and one CM-SR stage rack

System below using one CM-MD64 and CM-SR stage rack using coaxial cables only

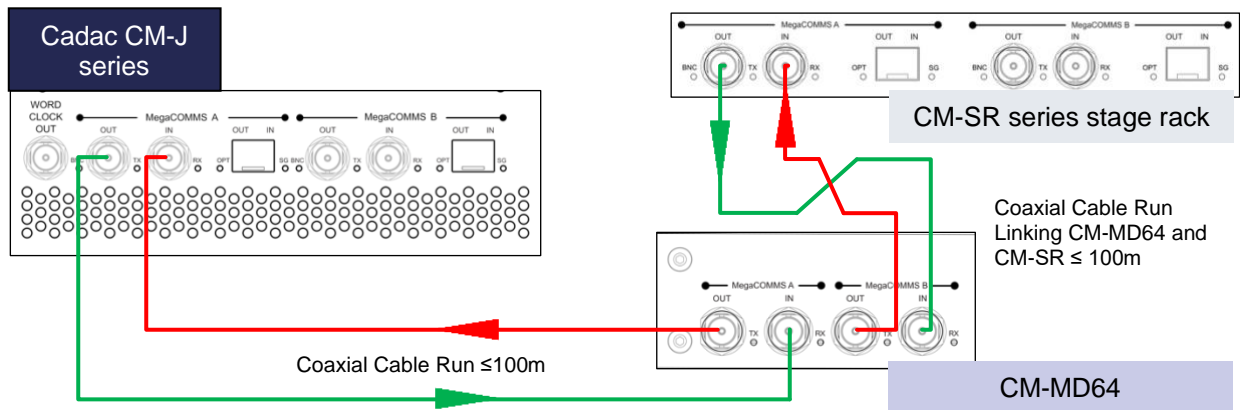

NOTE: With the system setup above MegaCOMMS *PORT A* on the first stage rack **MUST** be connected to the console.

System below using one CM-MD64 and CM-SR stage rack with the CM-SR using fibre optic cable

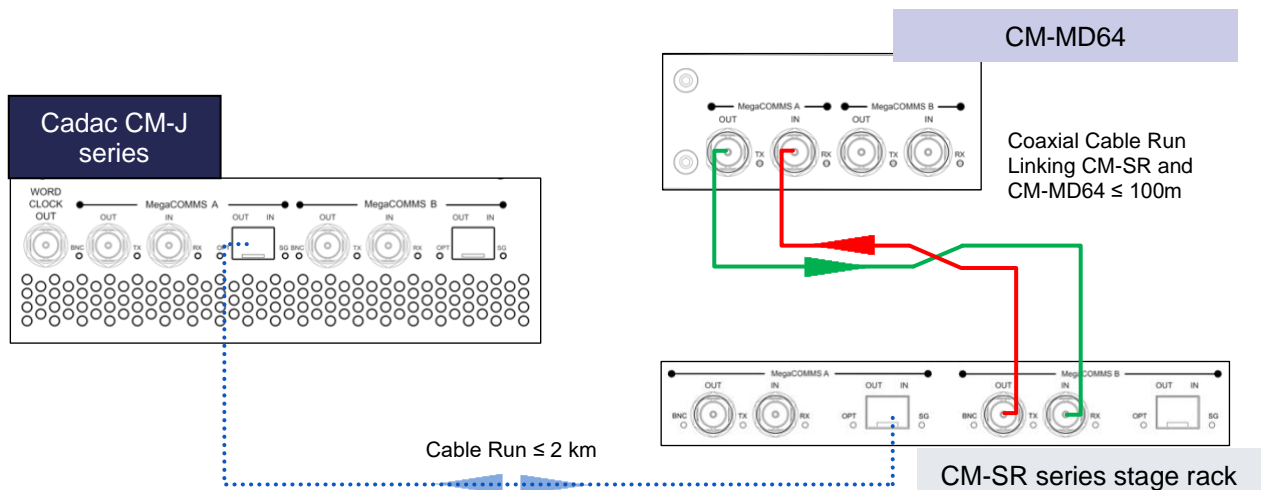

NOTE: With the system setup above MegaCOMMS *PORT A* on the first stage rack **MUST** be connected to the console.

NOTE: Only RG6 video cable suitable for 3G HD-SDI (High-Definition Serial Digital Interface) should be used for the Cadac MegaCOMMS connections. The cables should be terminated in BNC connectors of the appropriate type, and total system cable run should not exceed 100m (surface-to-stage rack or stage rack to stage rack as a snake). A suitable cable: Kramer bulk Type BC-1X.

Setting up the CM-MD64 for a MADI Network

The following section provides a guide on how to set up the Cadac CM-MD64.

Front Panel Dip Switch Settings

The table below shows how the unit can be configured via from Configuration DIP switch [3] on the front panel:

DIP Switch	Mode	ON	OFF
DIP 1	MADI Channel / Stream 1	COAX RX	OPTICAL RX
DIP 2	MADI Channel / Stream 2	COAX RX	OPTICAL RX
DIP 3	Clock Speed	96 kHz	48 kHz
DIP 4	SYNC	EXTERNAL	INTERNAL
DIP 5	SYNC Source	WORD CLOCK	MADI

Important Notes

- DIP switches 6, 7, 8 are set to OFF
- Definitions of EXTERNAL / INTERNAL operation above DO NOT relate to MegaCOMMS. The CM-DM64 will always follow MegaCOMMS when connected to a Cadac digital console.
- One MADI port Tx connection may not be routed to a Rx connection from the same port

Appendix A: Example System Configurations

This section shows 4 example configurations using the CM-MD64 to integrate a Third Party MADI unit - which is running at either 48 kHz or 96 kHz - into a MegaCOMMS network.

System 1

Cadac Console and Stage Rack running 64 bi-directional channel 48 kHz MADI stream to a Third Party MADI unit via the CM-MD64:

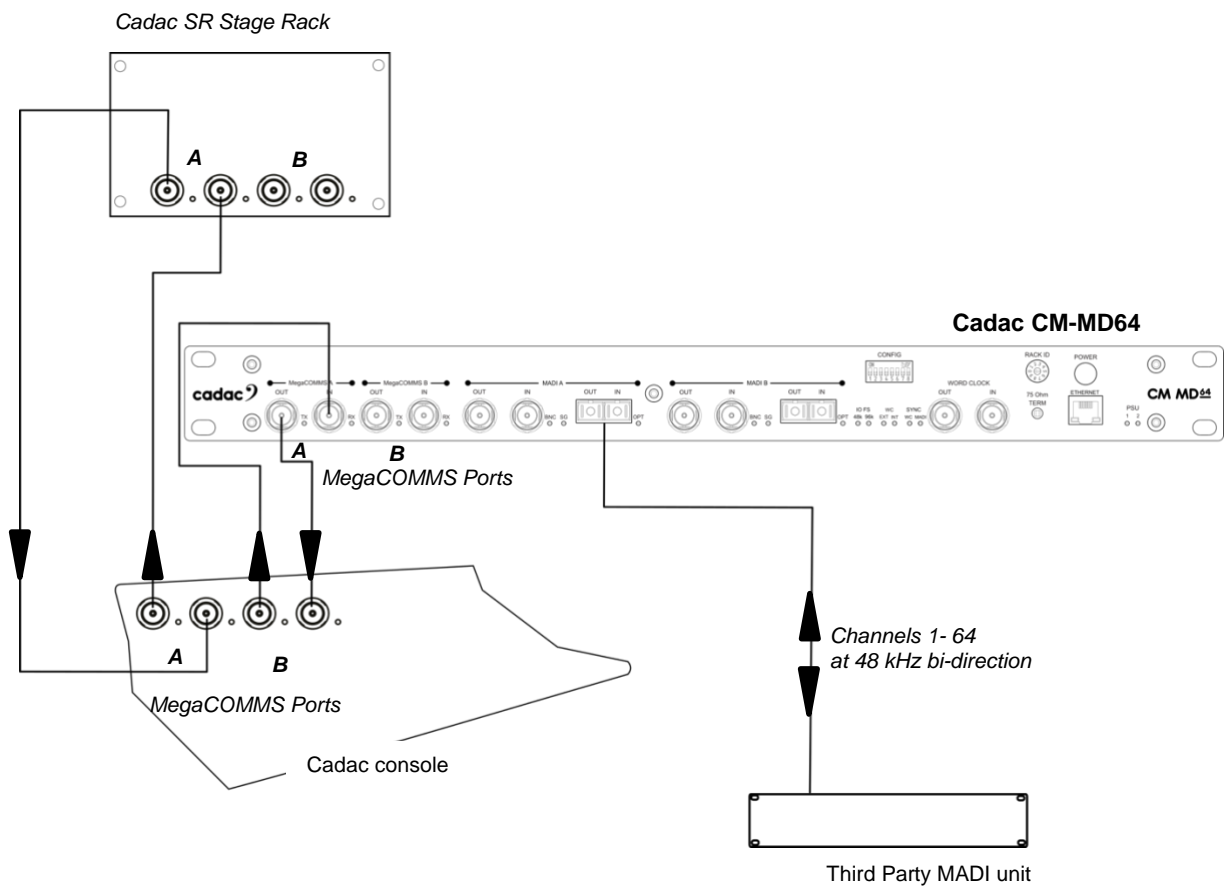

System 2

Cadac Console and Stage Rack running two 32 bi-directional channel 96 kHz MAD1 streams to a Third Party MAD1 unit via the CM-MD64. The system is also running a second pair of MegaCOMMS to the CM-MD64 as a back-up:

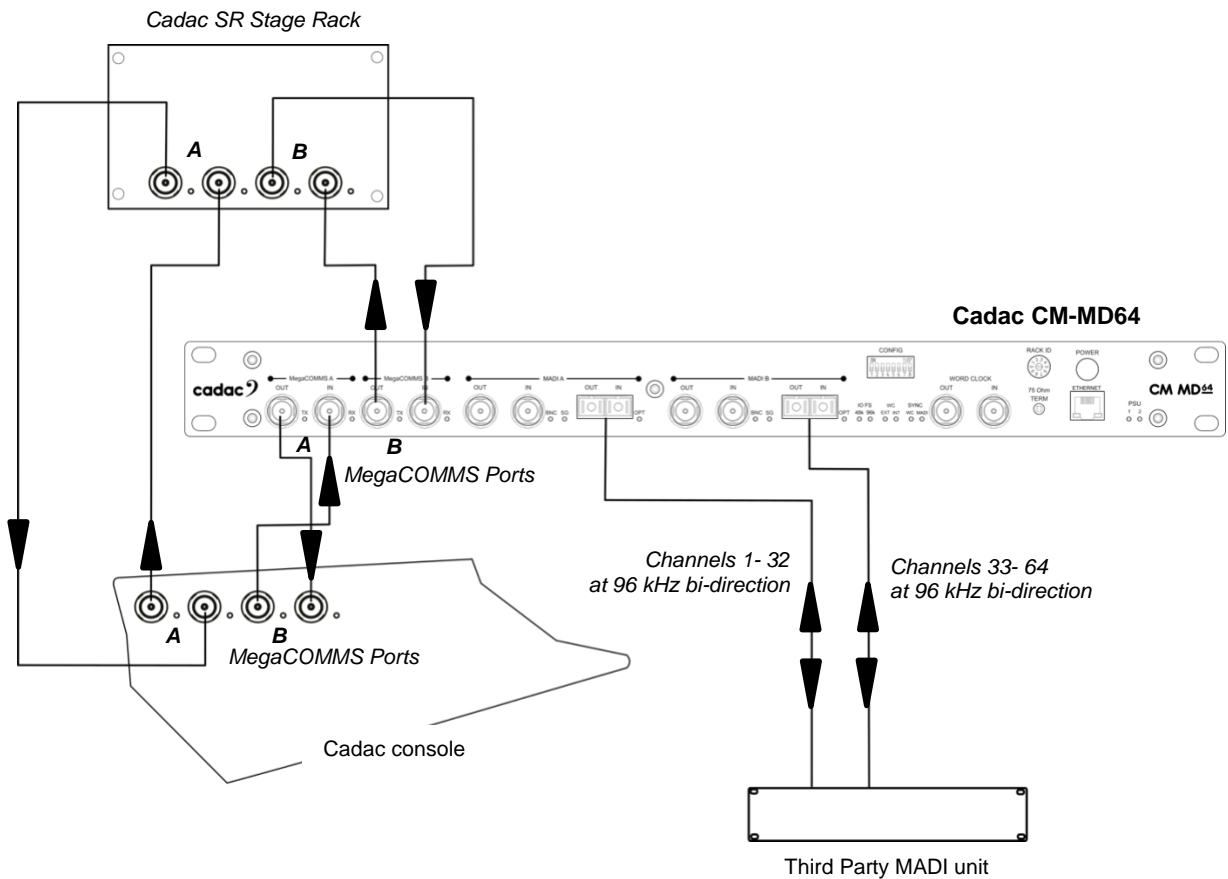

System 3

Cadac Console running one 64 bi-directional channel 48 kHz MADi stream to a Third Party MADi unit via the CM-MD64:

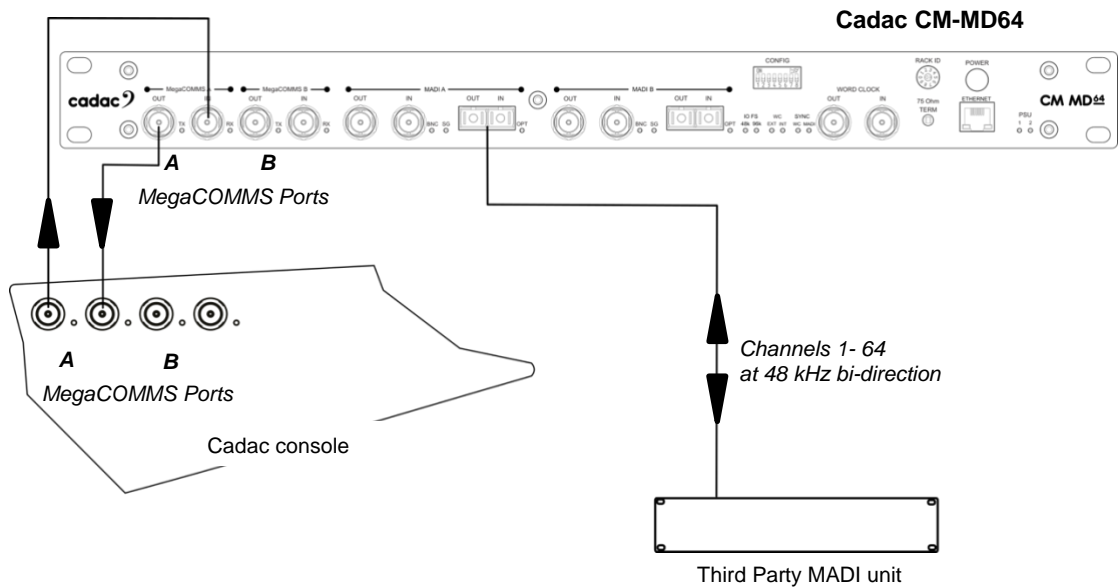

System 4

Cadac Console running two 32 bi-directional channel 96 kHz MADi streams to a Third Party MADi unit via the CM-MD64:

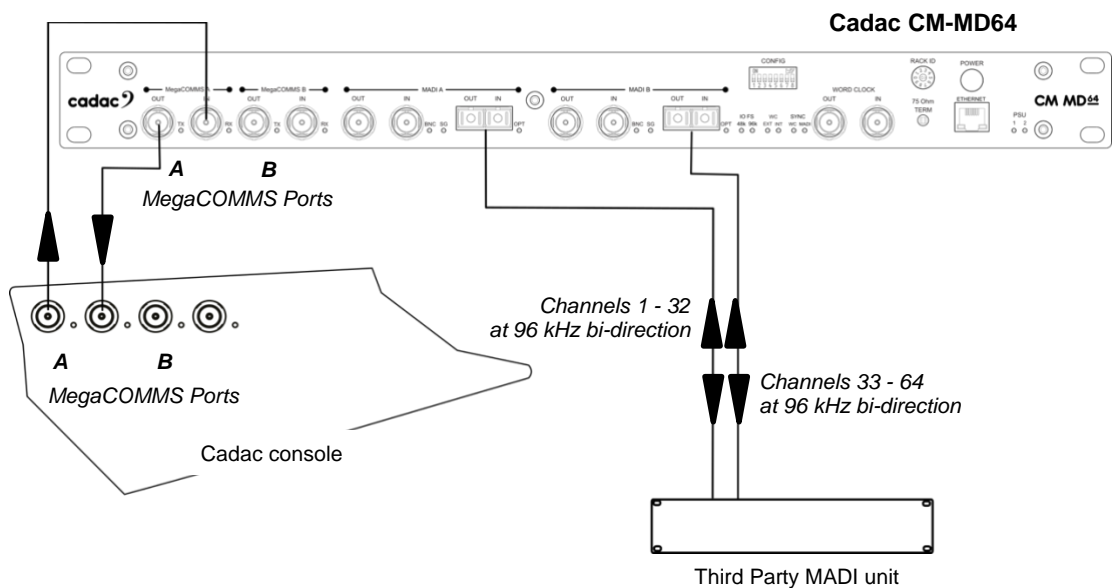

Appendix B: Updating Firmware

The CM-MD64 operating system undergoes a programme of continuous development, as a result the unit may be updated by loading new versions of the firmware as they become available. This can be done by connecting an Ethernet cable to the CM-MD64's front panel [11] linked to a Windows PC with the latest firmware file.

The latest firmware version can be downloaded from Support / Software Download page on the Cadac website.

Programming the FPGA

To programme the FPGA on the CM-MD64 you will require:

- A PC / laptop with a web browser (this procedure will not work with a Mac)
- Ethernet cable (Cat5 or Cat6)

To update the FPGA follow the instructions below:

- Set the network card on the PC to **IP address 169.254.1.2** and the **subnet mask to 255.255.0.0**.
- Power cycle the unit
Power off - wait 5 seconds - power on
- Connect the PC to the CM-MD64 unit via the Ethernet cable using the Ethernet port located on the unit's front panel.
- Start the web browser on the PC and type **MCOMMS_MADI/mpfsupload** into the address bar and press **Enter**
To find the CM-MD64's current FPGA version type MCOMMS_MADI into the address bar and press Enter
- When the page loads you should see **MPFS Image Upload** plus a **Choose File** and an **Upload** button
- Select **Choose File** and a file browser window should appear
- Browse to and open the **MComms_MADI_FPGA_*****_A**.bin** file
- Select **Upload** on the web page
Wait for up to 60 - 90 seconds and Upload successful will appear on the page
- **Programming the FPGA is complete**

When the FPGA Has Been Programmed

- Power cycle the CM-MD64
Power off - wait 5 seconds - power on
- Wait 8-10 seconds and LEDs should illuminate on the front of the unit
- The CM-MD64 is now fully programmed

Appendix C

Technical Specifications

General Specifications

PSU	<p>2 x internal PSUs</p> <p>100-240V AC 50-60 Hz</p> <p>Output requirements: +17 V, -17 V, +12 V</p>
MADI	<p>MADI (AES10 compliant) network bridge with up to 64 bi-directional channels at 48 kHz and 32 bi-directional channels at 96 kHz</p> <p>Operates up to 500m over optical fibre link and 200m coaxial copper link</p> <p>Optical transmission on SC Duplex connectors</p> <p>Cooper transmission on 75 ohm coaxial BNC connectors</p>
MegaCOMMS	<p>2 x Cadac MegaCOMMS on:</p> <ul style="list-style-type: none"> 4 x BNC connectors

Audio Specification

Sample Rate	96 kHz
Processing Delay	Sub 0.4 millisecond latency through complete signal chain
Internal Processing	40-bit floating point
ADC/DAC	24-bit
Frequency Response	20 Hz to 44 kHz + 0.5 / -1.5 dB
THD+N	better than 0.005% @unity gain, 10 dB input at 1 kHz
Channel Separation	better than 90 dB
Residual Output Noise	< -90 dBu (20 Hz – 20 kHz)
MIC EIN	< -127 dB with 200 Ohm source impedance
Maximum Output	21 dBu

Dimensions and Weights

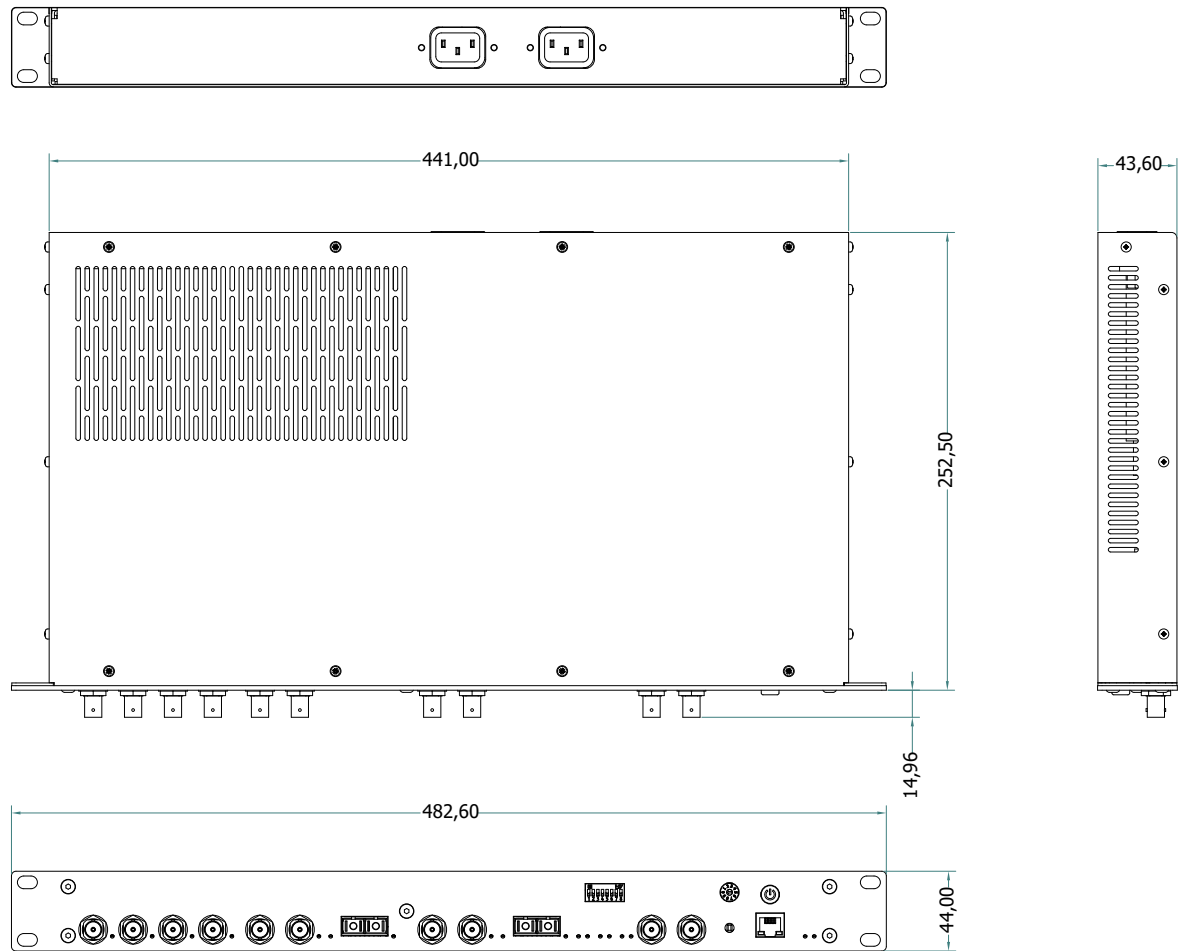

Weight: 4.5kg / 9.92lb (approx.)

Notes:

Cadac
One New Street
Luton
Bedfordshire
England
LU1 5DX

www.cadac-consoles.com

© Cadac 2024

All Rights reserved under International and Pan-American Copyright Conventions. All trademarks are the property of their respective owners.

No part of this publication may be reproduced in any form or by any means, whether mechanical or electronic, without the written permission of Cadac.

Due to Cadac's policy of continual improvement Cadac reserves the right to alter features, appearance and specifications without notice.

E&OE

All product names, logos, and brands are property of their respective owners. All company, product and service names used in this document are for identification purposes only. Use of these names, logos, and brands does not imply endorsement.