

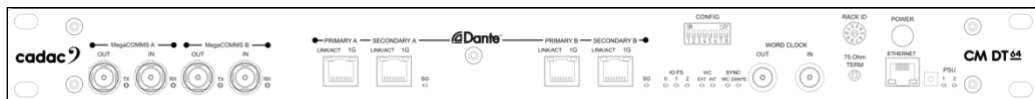

## Cadac Dante Network Bridge



### CM-DT64 Hardware Overview

Left Intentionally Blank

## Table of Contents

<b>Important Safety Information</b>	<b>5</b>
For US and CANADA Only	5
<b>General Precautions</b>	<b>6</b>
<b>Declaration of Conformity</b>	<b>7</b>
<b>Introduction</b>	<b>10</b>
<b>Overview</b>	<b>11</b>
Front Panel Controls	11
Rear Panel	12
Shipping Details	12
<b>Remote Network Bridge Units</b>	<b>13</b>
<b>Dante Bridge Overview</b>	<b>14</b>
<b>MegaCOMMS: Data Protocol</b>	<b>15</b>
<b>CM-DT64 Dante Bridge Hardware Overview: Front Panel</b>	<b>16</b>
Front Panel	16
<b>Connecting the Hardware</b>	<b>18</b>
MegaCOMMS	18
System Connection Options	19
<b>Setting up the CM-DT64 for a Dante Network</b>	<b>23</b>
<b>Channel Configurations Available *</b>	<b>24</b>
<b>Front Panel Dip Switch 1 - 2 - 3</b>	<b>25</b>
Settings for Different Sample Rates	25
<b>Front Panel Dip Switch 4 - 5</b>	<b>25</b>
Settings for Different WORD CLOCK Modes	25
<b>Important Notes</b>	<b>25</b>
<b>Appendix A: Example of Simple System Test Setup</b>	<b>26</b>
Rack ID Rotary Hex Switch Position	27
Configure the Dante system as follows:	27

<b>Appendix B: Audinate Dante Controller Details</b>	<b>28</b>
Routing Screen	28
Device Configuration Screen	29
Clock Status Screen	30
Networking screen	31
<b>Appendix C: Updating Firmware</b>	<b>32</b>
<b>Appendix D</b>	<b>33</b>
Technical Specifications	33
<b>Dimensions and Weights</b>	<b>34</b>
<b>Notes:</b>	<b>35</b>

## ***Important Safety Information***

CAUTION: These servicing instructions are for use by qualified personnel only. To reduce the risk of electric shock, do not perform any servicing other than that contained in the User Manual unless you are qualified to do so. Refer all servicing to qualified service personnel.

1. Read these instructions.
2. Keep these instructions.
3. Heed all warnings.
4. Follow all instructions.
5. Do not use this apparatus near water. Do not expose this apparatus to dripping or splashing and ensure that no objects filled with liquids, such as vases, are placed on this apparatus.
6. Clean only with a dry cloth.
7. Do not block any of the ventilation openings. Install in accordance with the manufacturer's instructions.
8. Do not install near any heat sources such as radiators, heat registers, stoves, or other apparatus that produce heat.
9. Only use attachments/accessories specified by the manufacturer.
10. Refer all servicing to qualified service personnel. Servicing is required when the apparatus has been damaged in any way, such as the power-supply cord or plug is damaged, liquid has been spilled or objects have fallen into the apparatus, the apparatus has been exposed to rain or moisture, does not operate normally, or has been dropped.
11. To completely disconnect mains power from this apparatus, the power supply cord must be unplugged.

### ***For US and CANADA Only***

Do not defeat the safety purpose of the grounding-type plug. A grounding-type plug has two blades and a third grounding prong. The wide blade or the third prong is provided for your safety. When the provided plug does not fit into your outlet, consult an electrician for replacement of the obsolete outlet.



The lightning flash with arrowhead symbol, within an equilateral triangle is intended to alert the user to the presence of an uninsulated "dangerous voltage" within the product's enclosure that may be of sufficient magnitude to constitute a risk of electric shock to persons.



The exclamation point within an equilateral triangle is intended to alert the user to the presence of important operating and maintenance (servicing) instructions in the literature accompanying the appliance.

## General Precautions

- Do not place heavy objects on the Network Bridge, expose it to sharp objects or handle the unit in any way that may cause damage, e.g., rough handling and /or excessive vibration.
- Do not subject the equipment to dirt, dust, heat or vibration during operation or storage. Never expose the Network Bridge to rain or moisture in any form. Should the unit become wet, turn it off and disconnect it from the mains without further delay. The Network Bridge should be given sufficient time to dry out before recommencing operation.
- When cleaning the Network Bridge, never use chemicals, abrasive substances or solvents.
- The Network Bridge should be cleaned using a soft brush and a dry lint-free cloth. For persistent marks, use a soft cloth and isopropyl alcohol. Switches and potentiometers do NOT require cleaning or lubrication.
- Keep these instructions for future reference. Follow all warnings in this manual and those printed on the console.
- The Network Bridge must be connected following the guidance in this manual. Never connect power amplifier outputs directly to the unit. Connectors and plugs must never be used for any other purpose than that for which they are intended.
- The Network Bridge's mains input must always be connected to correctly rated mains power as referred to in this manual. The mains input must, at all times, be connected to the local mains power supply using the supplied power cord. In cases where the supplied plug does not fit, a qualified electrician must be consulted.
- The power cord must be routed in such a way that the risks of accidentally stepping on it, stretching it or it being pinched are minimized.
- **WARNING! THIS EQUIPMENT MUST BE EARTHED!**
- Ventilation slots must never be covered or obstructed in any way, otherwise airflow required for safe operation may be restricted. Where the Network Bridge is to be operated in a flight-case, then this must be located in such a way that it allows for proper ventilation.
- Refer servicing to qualified technical personnel only.

## *Declaration of Conformity*

The following pages show the individual declarations of conformity, for both the CE and UKCA marks, for the Cadac CM-DT64 Dante audio network bridge.

We, SCC Audio Limited, of 1 New Street, Luton, Bedfordshire, LU1 5DX declare under our sole responsibility that the **Cadac CM-DT64** Dante bridge, as detailed below complies with the provisions of the following UKCA Directives and is eligible to bear the UKCA mark:

**CM-SR Series**

Product Type Number	Product Description	Serial number
Cadac CM-DT64	Network Bridge	0000000000

**Object of the declaration:**



The CM-DT64 is a 1U Dante to MegaCOMMS audio network bridge enabling Dante units to be incorporated within a MegaCOMMS audio network. It features A and B Dante Ethernet ports with redundancy, operates at either 96 kHz or 48 kHz and can handle up to 64 inputs and outputs.

**Assurance of conformance of the described product with the provisions of the stated UK Regulation is given through compliance to the following standards:**

- EMC Directive: **2014/30/EU**
- Low Voltage Directive: **2014/35/EU**

**The following harmonised standards and technical specifications have been applied:**

- Electrical Safety (LVD): **EN 62368-1:2014/AC:2015**
- Electromagnetic Compatibility: **EN55032:2015**
- EN55013:2013+A1:2016**
- EN61000-3-2:2019**
- EN61000-3-3:2013 + A1. 2019**
- EN61000-4-2:2009**
- EN61000-6-2:2019**
- EN55035:2017/A11:2020**

Our representative in the UK is SCC Audio Limited, located at 1 New Street, Luton, Bedfordshire, LU1 5DX.

**Note:** The EMC performance of a system component will be affected by the final installation, compliance to the stated EMC standards and conformance to the EMC Directive must be confirmed after installation by the final equipment installer. For guidance with respect to test conditions please visit our website at <https://cadac-sound.com>, or contact your local CADAC representative.

**Signed for on behalf of:**

Name of Authorised Signatory	Emily Watson
Signature of Authorised Signatory	
Position of Authorised Signatory	Head of R&D Cadac
Date	21 <sup>st</sup> October 2022
Date when first CE marked	1 <sup>st</sup> March 2014
Place where signed	Luton, UK



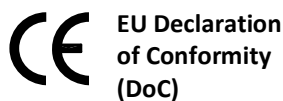

**CM-SR Series**

We, SCC Audio Limited, of 1 New Street, Luton, Bedfordshire, LU1 5DX declare under our sole responsibility that the **Cadac CM-DT64** Dante bridge, as detailed below complies with the provisions of the following European Directives and is eligible to bear the CE mark:

Product Type Number	Product Description	Serial number
Cadac CM-DT64	Network Bridge	0000000000

**Object of the declaration:**



The CM-DT64 is a 1U Dante to MegaCOMMS audio network bridge enabling Dante units to be incorporated within a MegaCOMMS audio network. It features A and B Dante Ethernet ports with redundancy, operates at either 96 kHz or 48 kHz and can handle up to 64 inputs and outputs.

**Assurance of conformance of the described product with the provisions of the stated EC Directive is given through compliance to the following standards:**

- EMC Directive: **2014/30/EU**
- Low Voltage Directive: **2014/35/EU**

**The following harmonised standards and technical specifications have been applied:**

- Electrical Safety (LVD): **EN 62368-1:2014/AC:2015**
- Electromagnetic Compatibility: **EN55032:2015**
- EN55013:2013+A1:2016**
- EN61000-3-2:2019**
- EN61000-3-3:2013 + A1. 2019**
- EN61000-4-2:2009**
- EN61000-6-2:2019**
- EN55035:2017/A11:2020**

**Note:** The EMC performance of a system component will be affected by the final installation, compliance to the stated EMC standards and conformance to the EMC Directive must be confirmed after installation by the final equipment installer. For guidance with respect to test conditions please visit our website at <https://cadac-sound.com>, or contact your local CADAC representative.

**Signed for on behalf of:**

Name of Authorised Signatory	Emily Watson
Signature of Authorised Signatory	
Position of Authorised Signatory	Head of R&D Cadac
Date	21 <sup>st</sup> October 2022
Date when first CE marked	1 <sup>st</sup> March 2014
Place where signed	Luton, UK

## Introduction

Thank you for purchasing the Cadac CM-DT64.

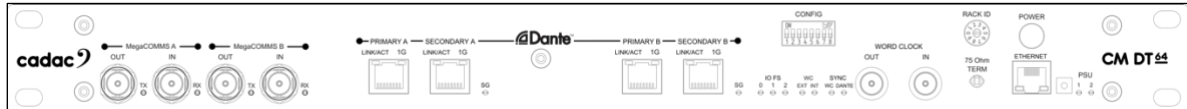

From its founding in 1968, Cadac’s products have become the benchmark for audio mixing consoles. The CM Series continues this tradition with a live performance digital audio system benefiting from Cadac’s innovative and acclaimed user interface, superlative audio quality and industry leading low latency infrastructure.

It expands the audio performance and features developed over a 50-year period of innovation within large-scale theatre and touring analogue desks and puts them within a compact, fixed-architecture digital system, featuring a “high-agility” user interface utilising a wide format touch screen. Professional sound engineers familiar with other digital consoles will find the transition to the Cadac workflow quick and intuitive.

Cadac’s attention to detail and high-quality audio circuitry remains at the core of Cadac’s CM Series design philosophy.

## Overview

The Cadac CM-DT64 unit is used as part of a larger audio system made up of multiple units: digital mixing console(s) and remote MegaCOMMS I/O device(s). The CM-DT64 is an audio network bridge enabling Dante units to be incorporated within Cadac's MegaCOMMS audio network.

**NOTE:** Due to an update to the unit's firmware, a number of front panel hardware controls are no longer functional as the configuration of the unit is done via the Dante Controller software. This now simplifies the set-up of the unit.

### Front Panel Controls

The front panel is divided in four operational areas:

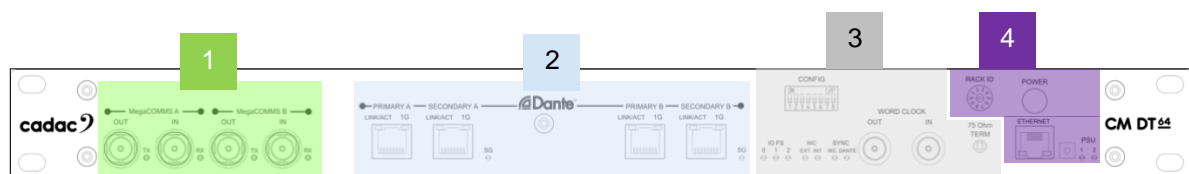

1. **MegaCOMMS Ports:** MegaCOMMS audio interconnections available on two pairs of redundant BNC connections.
2. **Dante Ports:** Two Dante network ports **A** and **B**, each with a primary and secondary connection.
3. **Dip Switch/ Word Clock:** The configuration of the unit is now set via the Dante Controller software; the Dip switches no longer have any effect on the unit's configuration. Word clock IN is also no longer active, however, Word clock OUT is still functional.
4. **Hex Switch, Power Switch and Ethernet:** The Hex switch sets the unit's rack number when connecting to a Cadac console. A front power button to power up the unit and an Ethernet port for firmware updates.

## Rear Panel

The only connections that are not on the front panel are the power connections for the dual internal, auto switching, power supplies. The connectors accept the standard and locking IEC cables.

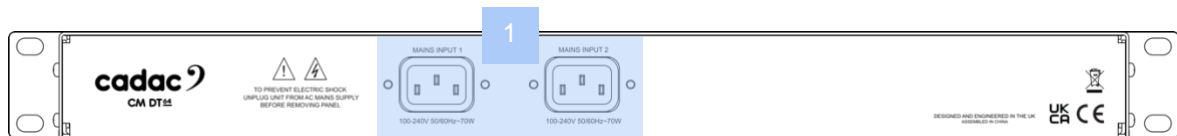

1. **PSU connectors:** The dual internal PSUs have an input range of 100-240 V AC~50-60Hz, the output requirements are +17 V, -17 V, +12 V, with a front mounted power switch. The unit is designed to run off one PSU, however when connected the second supply provides redundancy.

For further detailed explanation of the control surface please see section: [Dante Overview: Front Panel](#)

## Shipping Details

The stage rack is shipped in a cardboard box with the following additional items:

- 2 x IEC locking power cables

## Remote Network Bridge Units

Two remote network bridges are available:

- CM-DT64: 1U Dante Network Bridge: 64 inputs and outputs at 96 kHz, 88.2 kHz, 48 kHz or 44.1 kHz operation



- CM-MD64: 1U MADI Network Bridge: 64 inputs and outputs at 96 kHz, 88.2 kHz, 48 kHz or 44.1 kHz operation

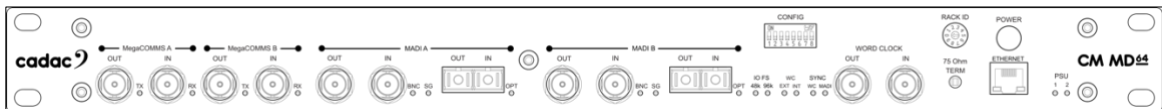

Up to two MegaCOMMS remote network bridges devices can be connected directly to the console.

## *Dante Bridge Overview*

The Cadac CM-DT64 is a 1U, Dante to MegaCOMMS audio network bridge, enabling Dante units to be incorporated within a MegaCOMMS audio network. The unit supports up to 64 bi-directional connections to map between MegaCOMMS ports and a Dante network.

The unit features A and B Dante Ethernet ports to provide the 64 input and output channel count at 96 kHz. Each has a primary and secondary connection; the secondary connections are for redundant network connections **only**.

CM-DT64 can operate at either 96 kHz providing 64 bi-directional channels using both **A** and **B** Dante ports, or 64 bi-directional channels at 48 kHz using Dante port **A** only. However, both Dante cards must be set to the same Word clock rate - even if only one card is being used.

The unit also has its own independent Word Clock OUT.

All MegaCOMMS audio connections are via co-axial. The co-axial ports glow either red or blue for Rx (receive) or Tx (transmit).

The CM-DT64 also comes as standard with redundant, auto switching, internal PSUs. Cooling of the unit is via convection.

## *MegaCOMMS: Data Protocol*

Communication between the unit and the control surface is via a proprietary Cadac high speed protocol called MegaCOMMS. The protocol uses high-speed 75 ohm coaxial cable terminated in BNC connectors or depending on the unit, via fibre optic cable using the duplex optical LC ports.

MegaCOMMS is a robust, TDM (time division multiplex) system. Control data is embedded within the data stream, so that no audio channels are sacrificed for this purpose. The high bandwidth available means that the current implementation of MegaCOMMS can carry 128 channels of 24-bit, 96 kHz audio, plus control data, plus clock, bi-directionally, up to 100 metres (328 ft) via a pair of RG-6 coaxial cables and up to 2km (1.24 miles) via single mode fibre on optical.

In addition to audio and control data, MegaCOMMS provides for accurate, phase-aligned clock distribution, by embedding timing markers in the data stream. This allows reliable, low-jitter synchronisation of all hardware elements within a network.

The simplest implementation of a MegaCOMMS network is the straightforward console-stage rack configuration. In this application, the console provides the clock and the stage rack synchronises itself once the connections are made. Total through-system propagation delay for this system, including all console processing and A/D to D/A conversions is an astonishing 37 samples (@ 96 kHz), or just under 400us. This compares with the many millisecond propagation delays usually found in most other similar systems.

Two interconnection paths are provided, A and B, each of which requires a transmit and receive cable. The maximum capacity of each path is 128 audio channels in each direction.

## CM-DT64 Dante Bridge Hardware Overview: Front Panel

### Front Panel

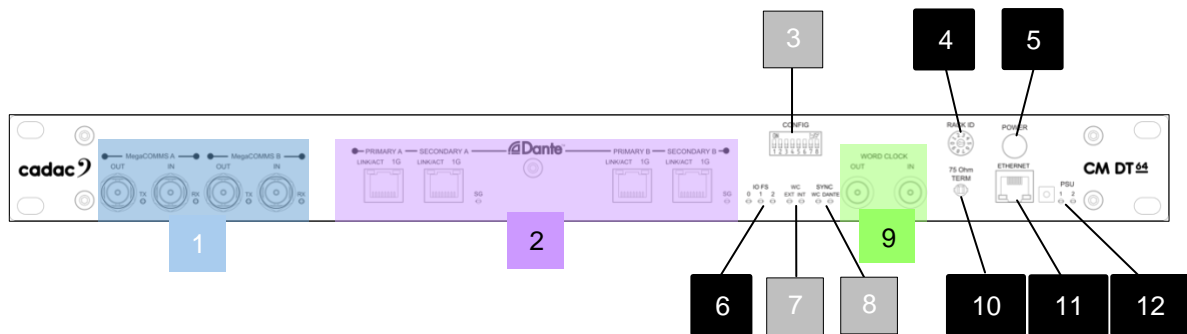

1. **MegaCOMMS ports:** 4 x RG6 BNC connectors - in 2 pairs - carry all audio and control data between the control surface and other MegaCOMMS devices such as stage racks and consoles. Each individual port has a signal present LED.
2. **Dante Ports:** Two Ethernet network ports **A** and **B** are available to provide the 64 bi-directional channel count at 96 kHz (32 input and output channels via each port). Each has a primary and secondary connection; the secondary connections are for redundant network connections **only**. Each A and B port has a signal OK SG-LED. Both Dante cards **A** and **B** must be set to the same Word clock rate - even if only one card is being used.
3. **Config:** The configuration of the unit is now set via the Dante Controller software. The Dip switches no longer have any effect on the unit configuration.
4. **Rack ID Hex Switch:** The hex switch controls the rack address and is set depending on how the unit is to be connected:
  - Set to '2' when connecting the CM-DT64 to a console, and it is to be used as RACK 1
  - Set to '3' when connecting the CM-DT64 to a console, and it is to be used as RACK 2

**NOTE:** Always set the rack address while the unit is OFF or restart the unit if changed while it was ON.
5. **POWER:** Switches the unit ON / OFF
6. **IO FS:** Indicates the sample rate (FS) of the inputs and outputs. For more information refer to the section: Channel Configurations Available \*



7. **WC:** Word Clock status. These LEDs no longer function. Status is shown in the Dante Controller software.
8. **SYNC:** Synchronisation status. These LEDs no longer function. Status is shown in the Dante Controller software.
9. **Word Clock IN / Word Clock OUT:** Word clock IN no longer is active. Word clock OUT - on BNC connectors for 75 ohm co-axial cable - to act as the synchronisation of the digital signal within the network.
10. **75 ohm switch:** This switch no longer functions as it applies to the Word clock IN connector.
11. **Network:** RJ45 Ethernet port for updating the unit's firmware. This is a standard PC network Gigabit Ethernet port.
12. **PSU indicators:** LEDs indicate the ON status of each of the two internal power supplies.

## Connecting the Hardware

### MegaCOMMS

Cadac's proprietary MegaCOMMS hi-speed data protocol is used to interconnect the network bridge to the console. The CM-DT64 Dante network bridge and the console have four BNC sockets to provide the main system data interconnection, labelled OUT (TX) A, IN (RX) A and OUT (TX) B, IN (RX) B:

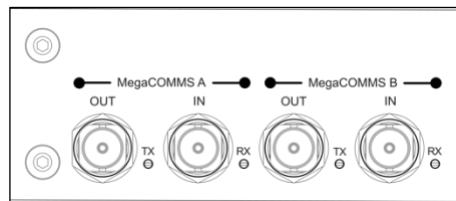

1: The CM-DT64 has two pairs of MegaCOMMS ports on BNC connectors

Cadac consoles have two pairs of BNC sockets, plus two optical ports for MegaCOMMS:

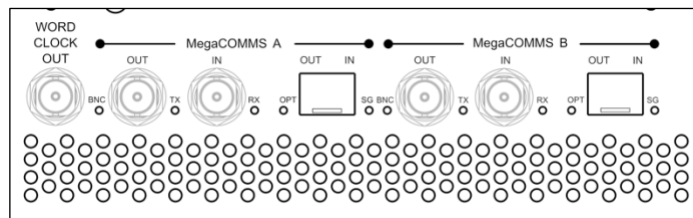

2: Cadac consoles have two pairs of MegaCOMMS ports on BNC connectors and two duplex optical LC ports

The two paths, A and B, carry identical and synchronous data, and can be used in various ways, depending on whether system redundancy is required. Providing a redundant path gives greater system robustness, as the CM-DT64 will automatically switch its comms to Path B if communication is lost on Path A, such as might occur if a cable is damaged. Note that the CM-DT64 is fully functional in all respects if only one coax TX / RX or optical path is connected.

## System Connection Options

The console and CM-DT64 should be connected using one of the system configurations shown over the next few pages. The diagrams depict systems in redundant or non-redundant configurations.

### IMPORTANT: Best Practice when Designing a System

With coaxial cable it is best practice **NOT** to tape power cables to the coaxial cable. This could lead to interference with the signal and result in unwanted audio artefacts, or in the worst case, total loss of audio. It is highly recommended that **all coaxial cables be connected** to the appropriate units **prior to powering** them on.

When designing a system, it is extremely important to ensure that **coaxial cable runs do not exceed 100m and fibre optic cables do not exceed 2km.**

When using **redundancy**, the optical and coaxial runs from the console to the unit (s) must not exceed 2km or 100m respectively - and must be of **similar lengths**. The coaxial link cables connecting the two units must not exceed 100m.

When designing a non-redundant, redundant or daisy chain system, MegaCOMMS port A or B from the console **MUST** be connected to **MegaCOMMS port A** - NOT port B - on the CM-DT64 and / or the stage rack. Any redundancy link cables must use ports B on both units.

### Console with a CM-DT64 and CM-SR stage rack: Non-Redundant System

System below using one CM-DT64 and CM-SR stage rack using coaxial cables only

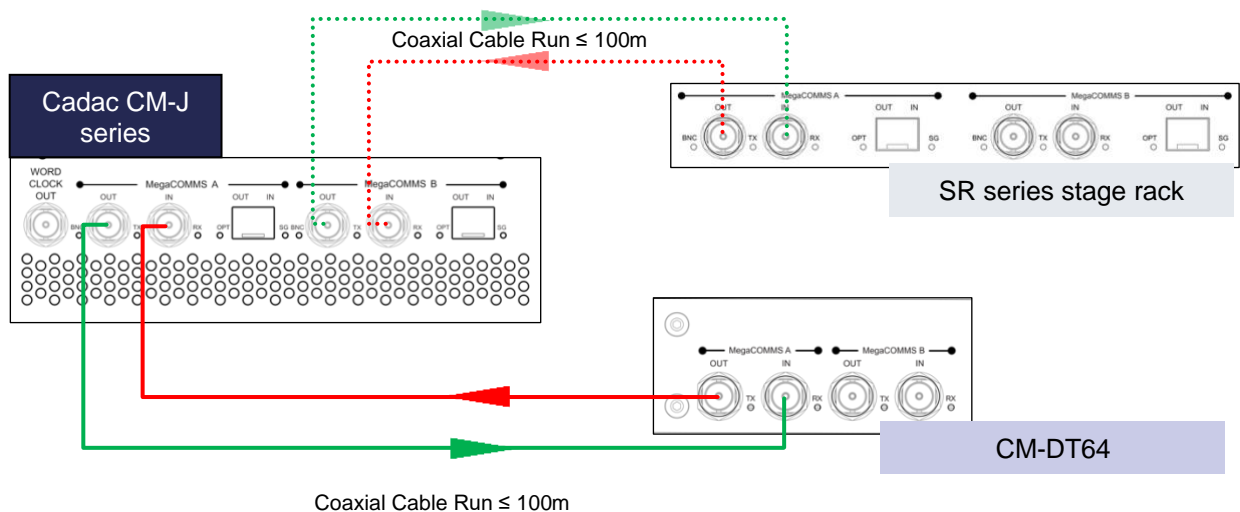

**NOTE:** With the system setup above MegaCOMMS *PORT A* on the CM-DT64 and stage rack **MUST** be connected to the console.

System below using one CM-DT64 and CM-SR stage rack with the CM-SR rack using fibre optic cable

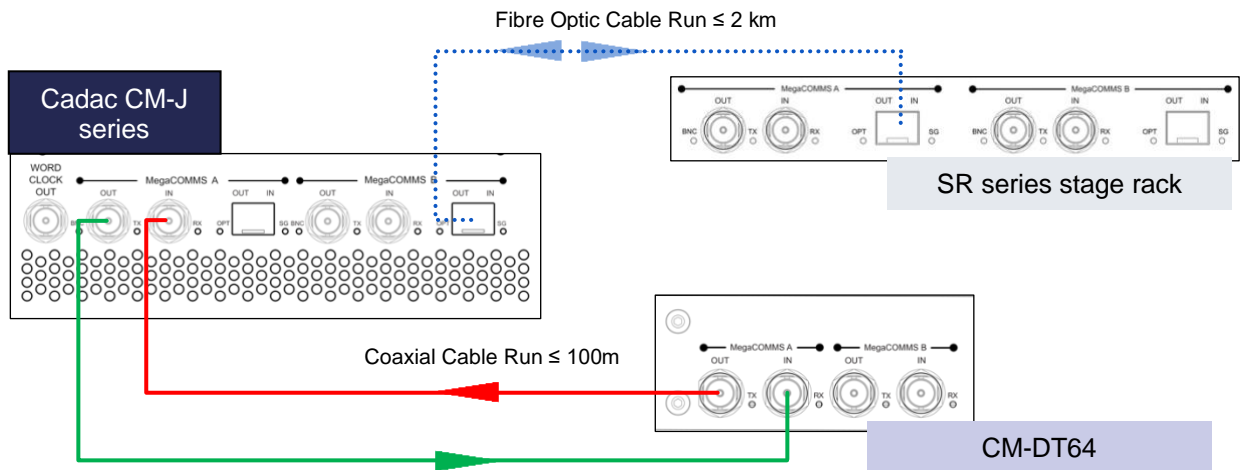

**NOTE:** With the system setup above MegaCOMMS PORT A on the CM-DT64 and stage rack MUST be connected to the console.

### Console and CM-DT64: Redundant System

System below using one CM-DT64 using coaxial cables only

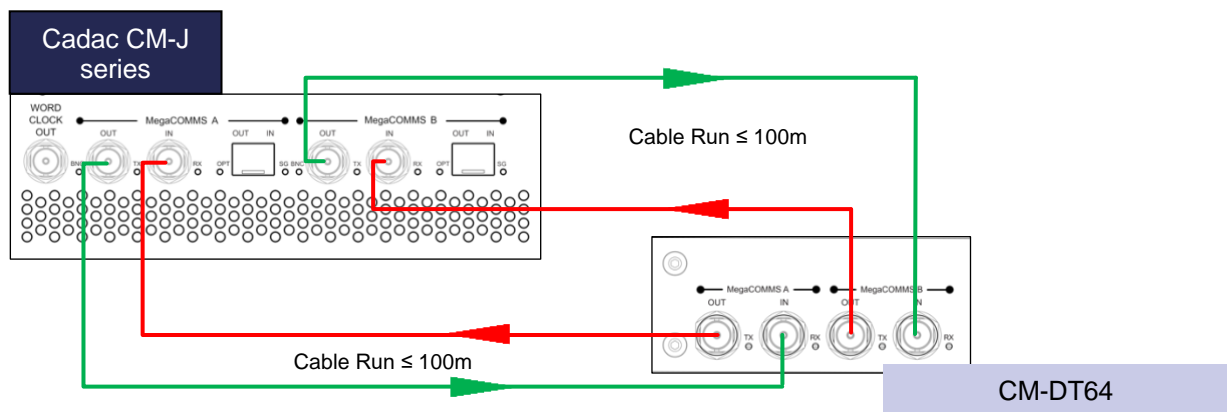

**NOTE:** The coaxial cables within the system must be of similar length.

System below using one CM-DT64 and CM-SR stage rack using coaxial cables only

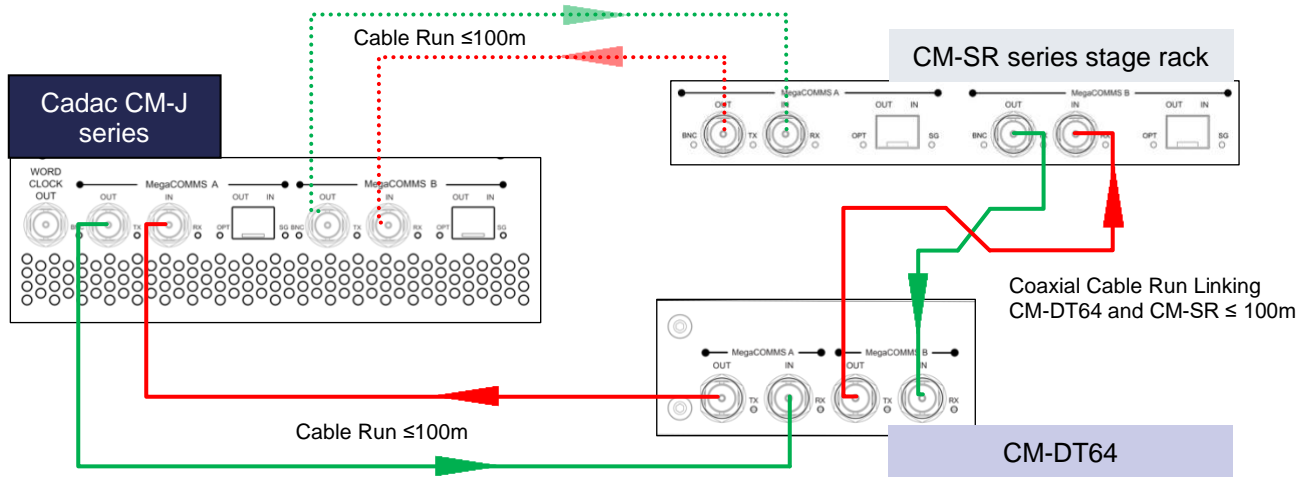

**NOTE:** With the system setup above MegaCOMMS *PORT A* on the CM-DT64 and stage rack **MUST** be connected to the console. The coaxial cables linking the console to the racks must be of similar length.

System below using one CM-DT64 and CM-SR stage rack with the CM-SR using fibre optic cable

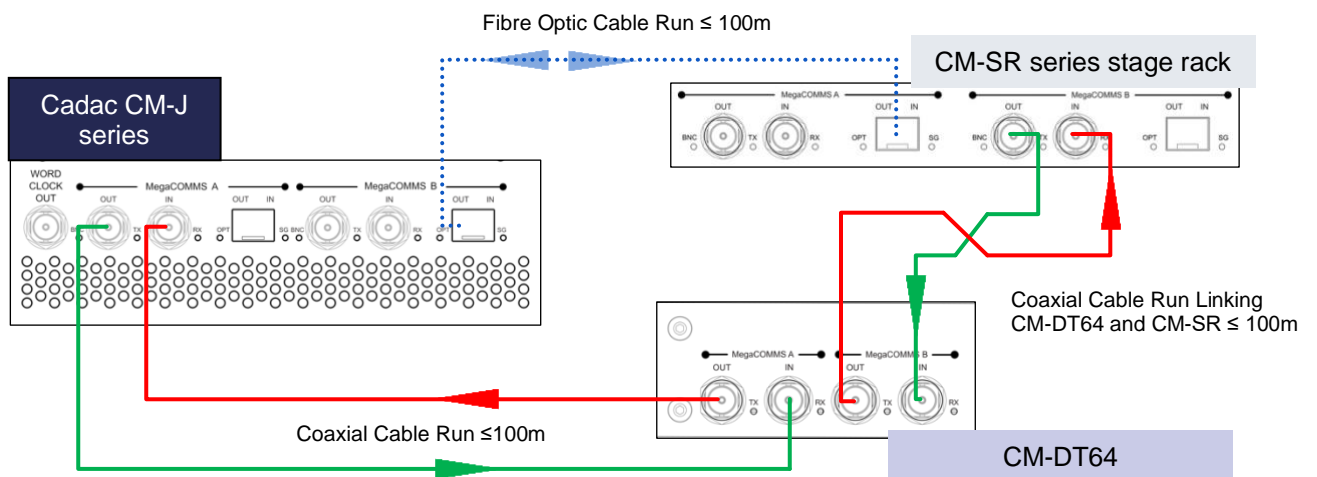

**NOTE:** With the system setup above MegaCOMMS *PORT A* on the CM-DT64 and stage rack **MUST** be connected to the console.

Console and daisy chaining one CM-DT64 and one CM-SR stage rack

System below using one CM-DT64 and CM-SR stage rack using coaxial cables only

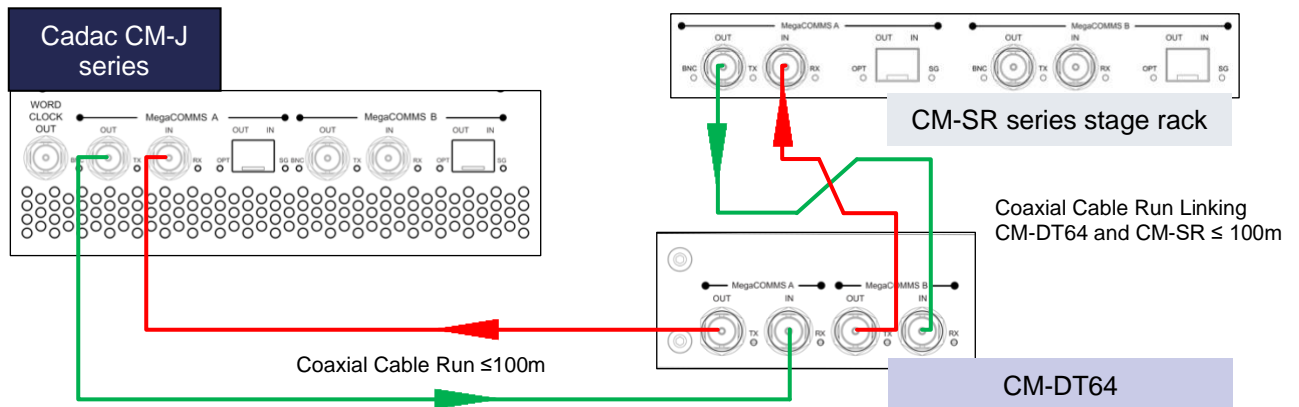

**NOTE:** With the system setup above MegaCOMMS *PORT A* on the first stage rack **MUST** be connected to the console.

System below using one CM-DT64 and CM-SR stage rack with the CM-SR using fibre optic cable

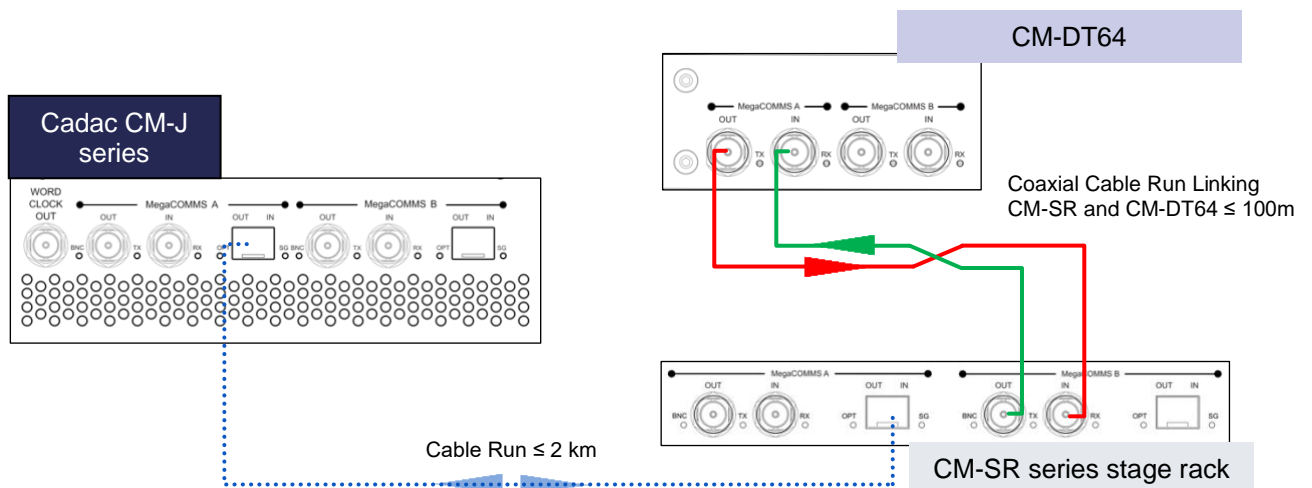

**NOTE:** With the system setup above MegaCOMMS *PORT A* on the first stage rack **MUST** be connected to the console.

**NOTE:** Only RG6 video cable suitable for 3G HD-SDI (High-Definition Serial Digital Interface) should be used for the Cadac MegaCOMMS connections. The cables should be terminated in BNC connectors of the appropriate type, and total system cable run should not exceed 100m (surface-to-stage rack or stage rack to stage rack as a snake). A suitable cable: Kramer bulk Type BC-1X.

## Setting up the CM-DT64 for a Dante Network

The following sections provide a guide on how to set up the Cadac CM-DT64.

The following Audinate™ software is also required in order to use the CM-DT64 on a Dante network:

- **'Dante™ Controller'**, provided free by Audinate™, provides remote control and set up of all Dante equipment attached to a given Dante audio network.

Follow the link for the **Dante™ Controller** software:

[www.audinate.com/products/software/dante-controller](http://www.audinate.com/products/software/dante-controller)

- **'Dante™ Virtual Soundcard'**, which requires a separate software license, is needed to send / receive audio on a Dante network to / from a local DAW or media player.

Follow the link for the **Dante™ Virtual Soundcard** software:

[www.audinate.com/products/software/dante-virtual-soundcard](http://www.audinate.com/products/software/dante-virtual-soundcard)

## Channel Configurations Available \*

Channel configuration per Dante port dependent on sample rate selected:

Fsample	Port A I/O	MegaCOMMS mapping	Port B I/O	MegaCOMMS mapping
44.1 / 48 kHz	64	1-64	Not used	-
88.2 / 96 kHz	32	1-32	32	33-64

Both Dante cards must be set to the same Word clock rate - even if only one card is being used.

Below are the front panel status LEDs that indicate the Word clock rate of the CM-DT64:

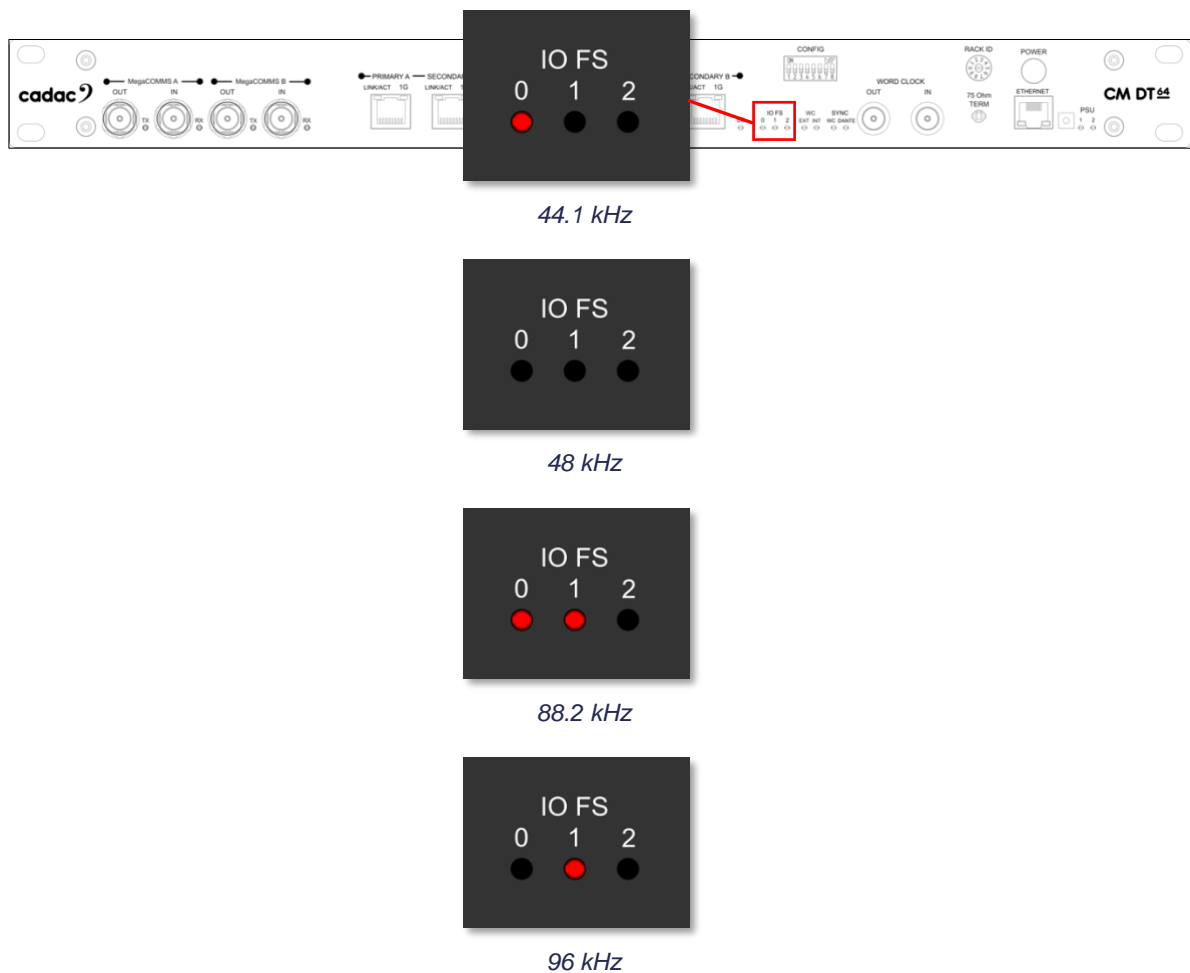

MegaCOMMS to Dante audio channel connections are configured on the routing page of the Dante Controller.

Dante Port A **must always** be connected when using CM-DT64.



### Front Panel Dip Switch 1 - 2 - 3

#### **Settings for Different Sample Rates**

*This function is now done via the **Dante Controller** software.*

### Front Panel Dip Switch 4 - 5

#### **Settings for Different WORD CLOCK Modes**

*This function is now done via the **Dante Controller** software.*

### Important Notes

- \* Dante port connections are identified via MAC addresses on the Dante Controller. Each port on all CM-DT64 units has a unique MAC address. The User must work out the MAC address of each unit, and port, by connecting one at a time to the network, and observing what device (MAC address) appears on the controller.*
- One Dante port Tx connection may not be routed to a Rx connection from the same port

**Appendix A: Example of Simple System Test Setup**

This is the simplest test to configure, as it requires no DAW or digital audio on the PC and no virtual soundcard software (this is licenced software and costs money!).

Connect units as shown below, apply power and switch on:

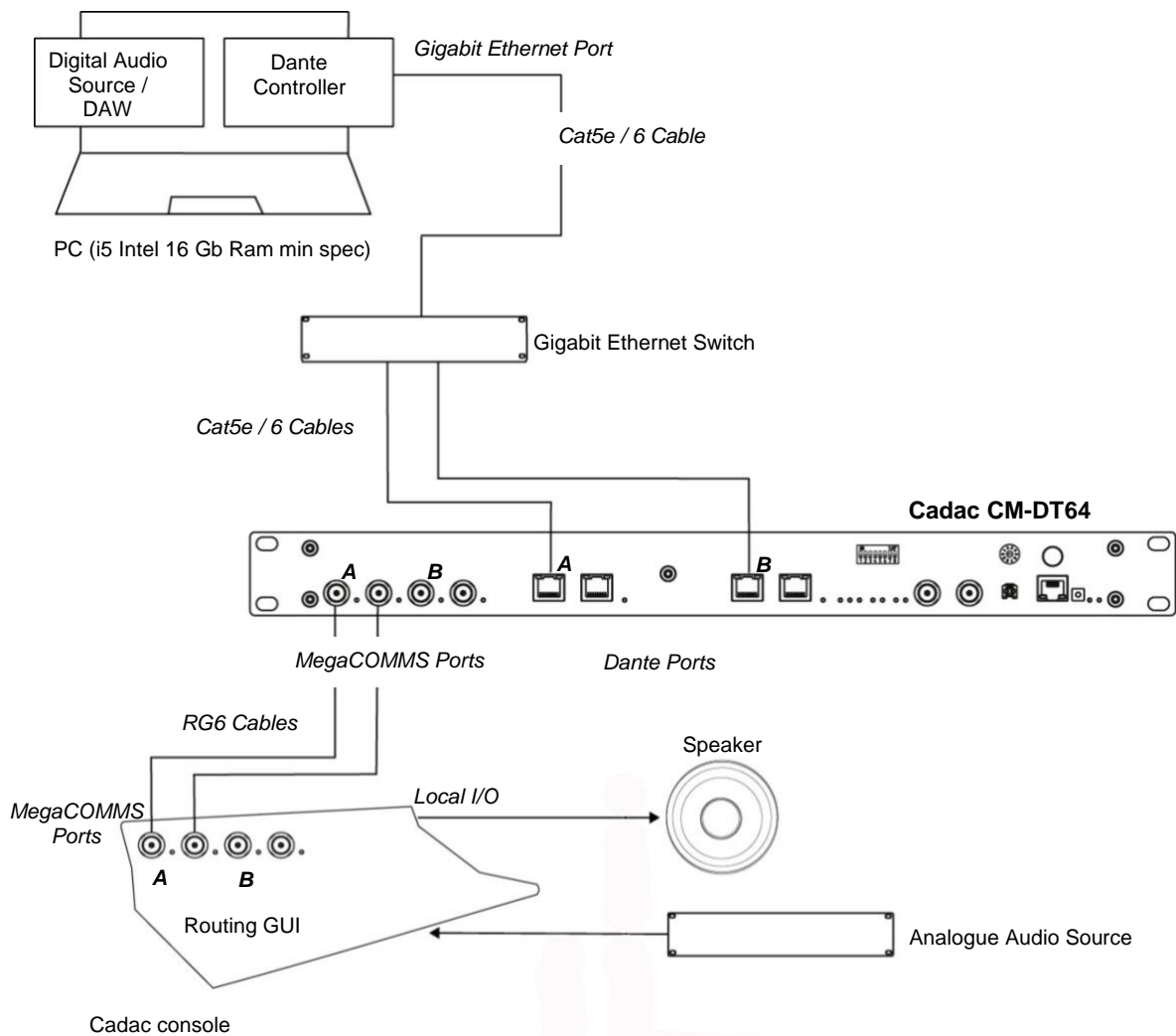

## ***Rack ID Rotary Hex Switch Position***

Select address **2** on the CM-DT64 rotary Hex switch

**NOTE:** Always set the rack address while the unit is OFF or restart the unit if changed while it was ON.

Check Power switch LED is illuminated

Check all BNCs illuminated

Check that the MegaCOMMS LEDs Tx and Rx are illuminated

Check that Dante **Port A** Ethernet LEDs are active

## ***Configure the Dante system as follows:***

CM-DT64, MegaCOMMS address	2 (only one CM-DT64 in the system)
Dante controller, Device view, Device config.	Port A – 96 kHz, Port B – 96 kHz
Dante controller, Routing map*	Connection 1 Port A CH1 to Port B CH1
Dante controller, Clock Status, Primary status	Port A or B operating as WORD CLOCK

Apply analogue audio source to local Mic IN on the console

Connect speaker to local Line OUT on the console

Select CH1 routing on the console GUI:

Input set to analogue audio source port

Send set to Dante 1 port 1

Select CH1 routing on the console GUI

Input set to Dante1 port 33

Send set to speaker port

At this point an audio path should now exist between the two analogue ports on the console. This will be utilising both Dante Port A and B on the CM-DT64.

***\*Important Note:*** *Where audio is routed from Port A to B this method is the only way the audio loopback will work on the CM-DT64. You cannot connect between channels on the same ports!!!!*

## Appendix B: Audinate Dante Controller Details

This program may be downloaded from the Audinate™ website.

Link: [Dante Controller Software](#)

It is free, but you may need to register to get a copy.

Once installed, the program automatically searches out any Dante enabled devices connected to the PC, and then allows you to configure each device.

There are **three** main screens that need to be considered.

### Routing Screen

The example below shows the two Dante ports found on a single CM-DT64 unit.

Note how the matrix allows connections to be set up between ports.

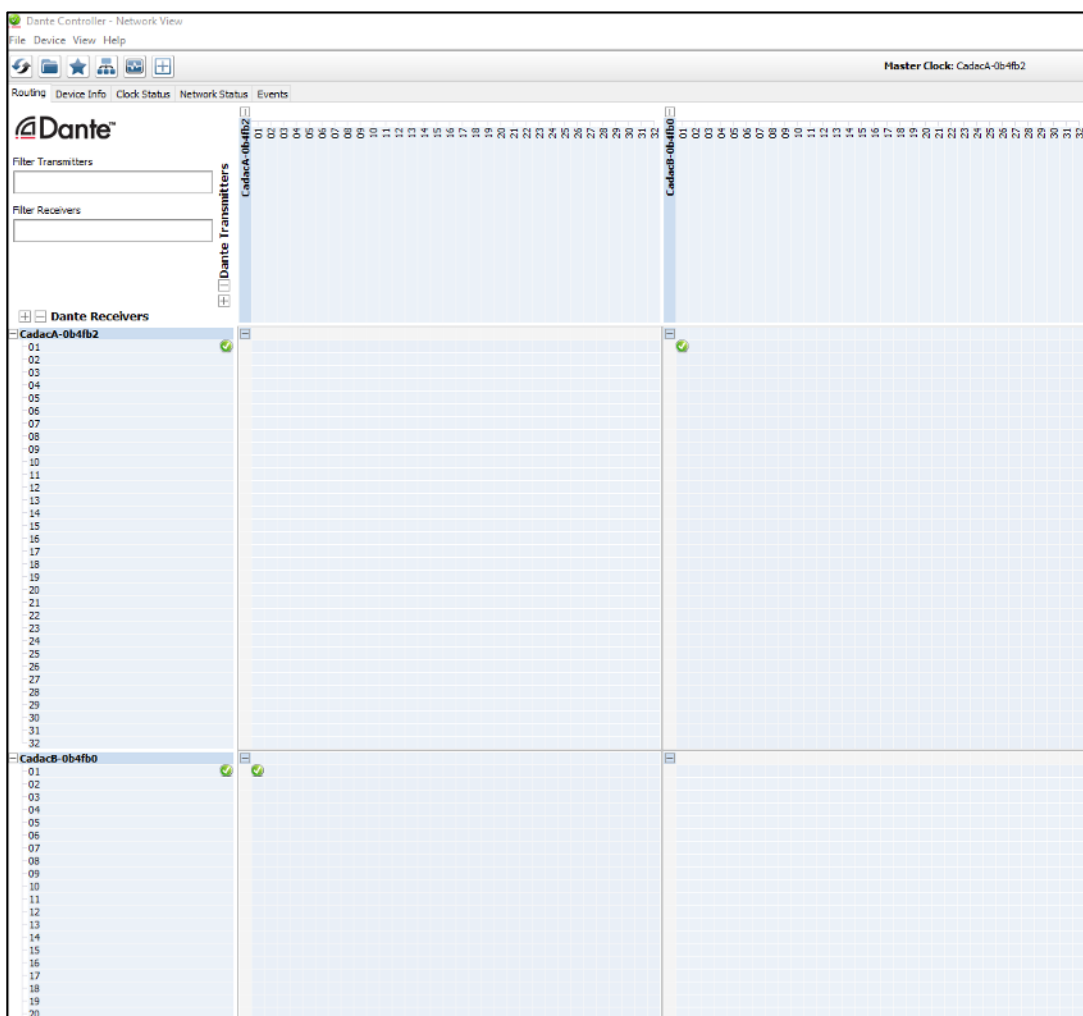

## Device Configuration Screen

The screen below demonstrates how the required sample frequency should be set-up for each device (separate screens will exist for each Dante port).

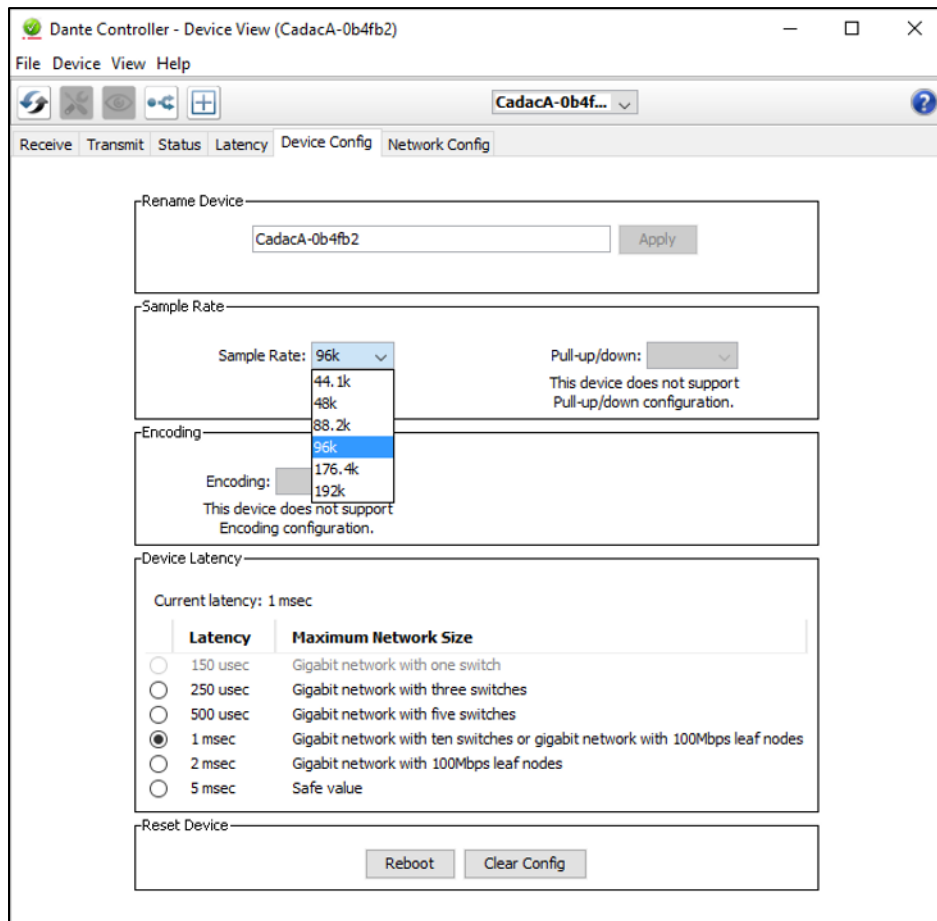

## Clock Status Screen

The screen below shows how each Dante port is running - either FOLLOWING or as the WORD CLOCK - in the Dante system.

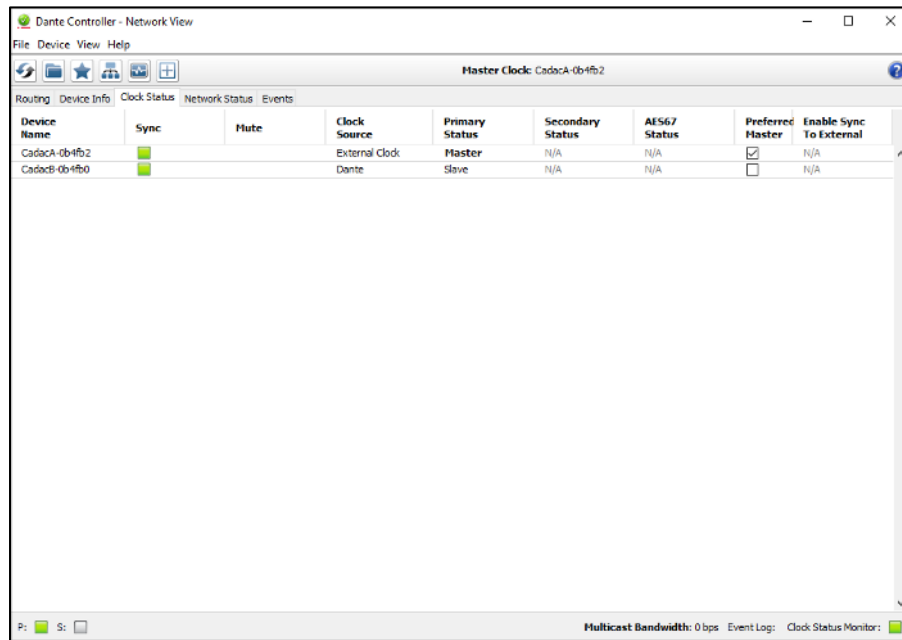

Device Name	Sync	Mute	Clock Source	Primary Status	Secondary Status	AES67 Status	Preferred Master	Enable Sync To External
CadacA-0b4fb2	<input checked="" type="checkbox"/>	<input type="checkbox"/>	External Clock	Master	N/A	N/A	<input checked="" type="checkbox"/>	N/A
CadacB-0b4fb0	<input checked="" type="checkbox"/>	<input type="checkbox"/>	Dante	Slave	N/A	N/A	<input type="checkbox"/>	N/A

At the bottom of the window, there is a status bar showing: P:  S:  Multicast Bandwidth: 0 bps Event Log: Clock Status Monitor:

## Networking screen

The screen below demonstrates how each CM-DT64 port is running, either as SWITCHED or REDUNDANT. Normally this should be set and left as **SWITCHED**.

**Only** when you are implementing a fully redundant Dante network should you select **REDUNDANT**.

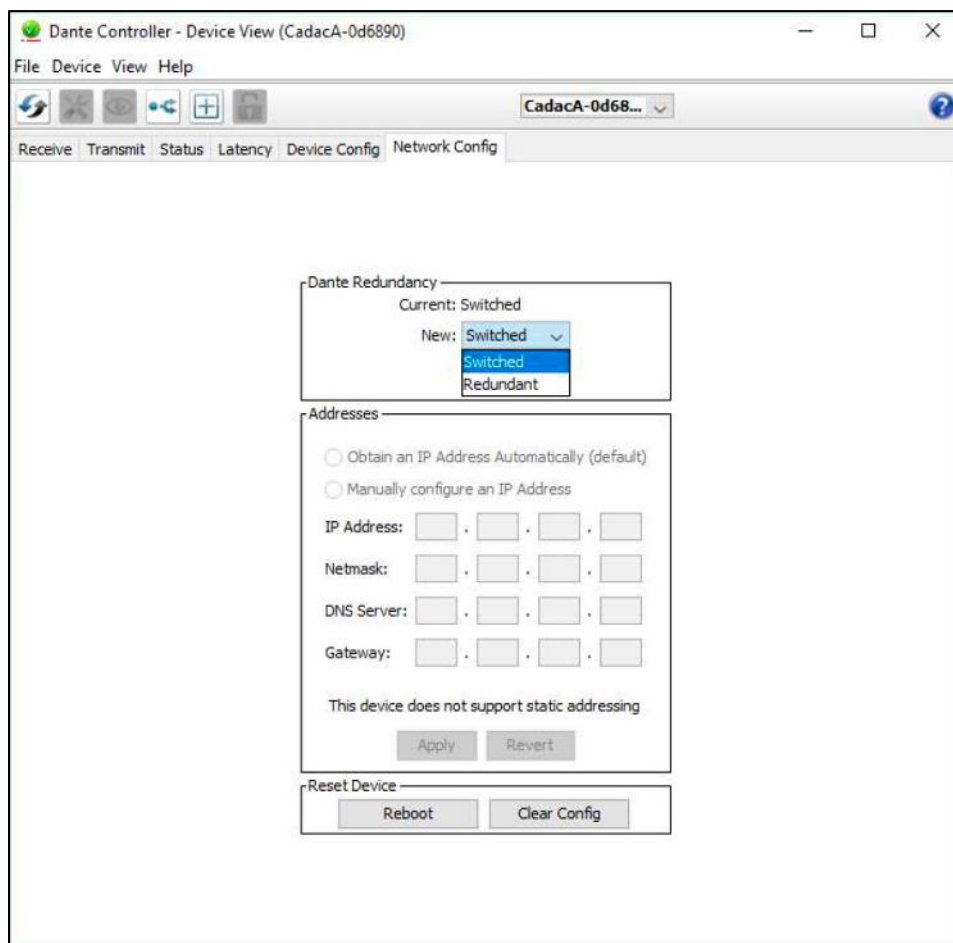

## Appendix C: Updating Firmware

The CM-DT64 operating system undergoes a programme of continuous development, as a result the unit may be updated by loading new versions of the firmware as they become available.

This can be done via Dante's "Dante Updater". Dante Updater is a desktop application that allows you to update the Dante firmware and software on Dante hardware devices. It is installed automatically when you install Dante Controller, which can be downloaded from Dante's website - along with instructions - <https://www.audinate.com/products/software/dante-controller>.

The application is linked to an online database containing the latest firmware update files.

UPDATE	DEVICE NAME	MANUFACTURER	MODEL NAME	STATUS	PRODUCT VERSION	LATEST PRODUCT VERSION	DANTE VERSION	LATEST DANTE VERSION
<input checked="" type="checkbox"/>	Amp1-CH	Weyland	D10	Out of date	1.0.1	1.1.0	4.0.1.2	4.1.0.3
<input checked="" type="checkbox"/>	Desk-CH-Main	Cyberdyne	T-1000	Out of date	1.0.0	2.0.0	4.1.0.3	4.2.0.6
<input checked="" type="checkbox"/>	Stagebox-CH	Cyberdyne	T-850	Out of date	1.2.4	1.4.0	4.1.0.1	4.1.1.0
<input checked="" type="checkbox"/>	Desk-CH-Mons	Cyberdyne	T-1000	Out of date	1.0.0	2.0.0	4.1.0.3	4.2.0.6
<input type="checkbox"/>	Amp2-CH	Weyland	D8	Out of date	1.0.1	1.1.0	4.0.1.2	4.1.0.3
<input type="checkbox"/>	Record-CH	Tyreil Corp	N6MAA	Out of date	2.1.0	2.4.3	4.1.1.0	4.1.2.2

9: Dante's "Dante Updater" window

When the application is connected to a Dante network, it scans the network and identifies the firmware versions for each discovered Dante device.

If newer firmware for any device is available in the online database, you can update the device using the online file, or download the firmware file to your local machine for offline use.

**Note:** The CM-DT64 has two Dante cards – both cards will need to be updated at the same time.



## Appendix D

### Technical Specifications

#### General Specifications

PSU	<p>2 x internal PSUs</p> <p>100-240V AC 50-60 Hz</p> <p>Output requirements: +17 V, -17 V, +12 V</p>
Dante	<p>2 x Brooklyn cards</p> <p>32 inputs and 32 outputs simultaneous streams on each card at 96 kHz</p> <p>Audio buffering of up to 2000 samples per channel</p>
Comms	<p>2 x Cadac MegaCOMMS on:</p> <ul style="list-style-type: none"> <li>• 4 x BNC connectors</li> </ul>

*Dimensions and Weights*

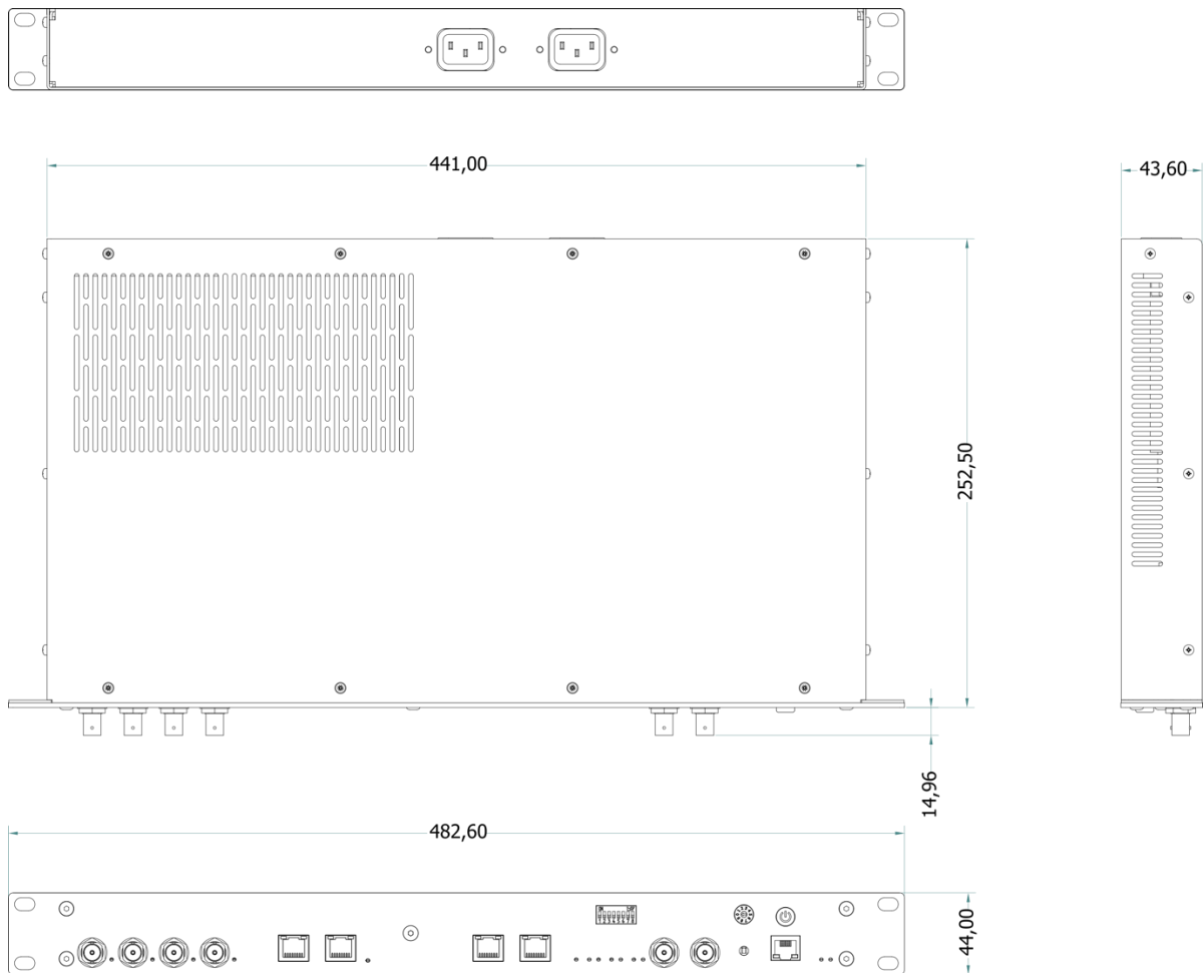

Weight: 4.5kg / 9.92lb (approx.)

Notes:

**Cadac**  
One New Street  
Luton  
Bedfordshire  
England  
LU1 5DX

[www.cadac-consoles.com](http://www.cadac-consoles.com)

**© Cadac 2024**

All Rights reserved under International and Pan-American Copyright Conventions. All trademarks are the property of their respective owners.

No part of this publication may be reproduced in any form or by any means, whether mechanical or electronic, without the written permission of Cadac.

Due to Cadac's policy of continual improvement Cadac reserves the right to alter features, appearance and specifications without notice.

**E&OE**

All product names, logos, and brands are property of their respective owners. All company, product and service names used in this document are for identification purposes only. Use of these names, logos, and brands does not imply endorsement.